

Haier Biomedical



Manual of medical centrifuge

Certificate of Quality

checker:

Model:
LX-185T100R



Manufacturer:
Qingdao Haier Biomedical Technology Co.,Ltd.
Address:
No. 280 Fengyuan Road, High-tech Zone, 266111
Qingdao, Shandong, P.R. China
Web:www.haiermedical.com
Revision Date:04/2023
Version:10rd,2023
Dedicated code:0270504070
V13026

Haier Biomedical
Makes Life Better

- Please read this manual carefully before use.
- The company reserves the right to interpret this manual.
- Please keep the Manual with invoice properly after reading.
- Product technology or software may subject to upgrade without prior notice.
- The appearance of material object shall prevail.

Contents

Safety Precautions	1
Precautions for Use	4
Product introduction.....	8
Structural characteristics and working principle	10
Installation and commissioning.....	11
Description of operation function interface	15
Use and operation	24
Fault alarm treatment	26
Fault alarm treatment	28
Circuit diagram	30
Specification • packing list	31
Electromagnetic compatibility requirements	33

Electromagnetic compatibility requirements

Table 1

Guidance and manufacturer's declaration - electromagnetic emissions	
Emissions test	Compliance
RF emissions CISPR 11	Group 1
RF emissions CISPR 11	Class A
Harmonic emissions IEC 61000-3-2	Not Applicable
Voltage fluctuations/ flicker emissions IEC 61000-3-3	Not Applicable

Table 2

Guidance and manufacturer's declaration - electromagnetic Immunity		
Immunity Test	Test level	Compliance level
Electrostatic discharge (ESD) IEC 61000-4-2	±4 kV contact ±8 kV air	±4 kV contact ±8 kV air
Electrical fast transient/burst IEC 61000-4-4	±1 kV power supply lines ±0,5 kV signal input/output 5 kHz repetition frequency	±1 kV power supply lines 5 kHz repetition frequency
Surge IEC 61000-4-5	±0,5 kV differential mode ±1 kV common mode	±0,5 kV differential mode ±1 kV common mode
Voltage dips, short interruptions and voltage variations on power supply input lines IEC 61000-4-11	0 % UT; 0,5 cycle 0 % UT; 1 cycle 70 % UT ; 25/30 cycles 0 % UT; 250/300 cycle	0 % UT; 0,5 cycle 0 % UT; 1 cycle 70 % UT; 25/30 cycles 0 % UT; 250/300 cycle
Conducted RF IEC61000-4-6	3 V 0,15 MHz – 80 MHz 80 % AM at 1 kHz	3 V 0,15 MHz – 80 MHz 80 % AM at 1 kHz
Radiated RF IEC61000-4-3	3 V/m (80 MHz to 1 GHz; 1,4 GHz to 6 GHz) 80 % AM at 1 kHz	3 V/m (80 MHz to 1 GHz; 1,4 GHz to 6 GHz) 80 % AM at 1 kHz
NOTE UT is the a.c. mains voltage prior to application of the test level.		

Rotor No.	Rotor type	Rotor capacity (ml)	Maximum speed (r/min)	Maximum centrifugal force (×g)
11	Cliniconic angle rotor	18x15	5000	4749
12	Cliniconic angle rotor	6x50 / 15	5000	3577
13	Cliniconic angle rotor	6x100	4800	3348
14	Swinging buckets rotor	Microplate	4500	2287
	Microplate buckets	2x96-well plates	4500	2287
15	Swinging buckets rotor	4x50	4200	2770
Optional	Buckets	4x5x10 / 7	4200	2770
Optional	Adapter	5	50/set	50/set
Optional	Buckets	4x2x15	4200	2770
Optional	Buckets	4x1x50	4200	2770

Packing list

Sequence No.	Category	Name	Quantity	Unit
1	Main body	Host	1	Set
2	Accessories	Power cord	1	Piece
3		Fuse	5	Pcs
4	Tools	T-type hexagon wrench	1	Pcs
5	Files	Operation manual	1	Copy

Safety Precautions

Dear Haier users,
Hello! Thank you for choosing Haier Medical Centrifuge. For better use of this manual and the product and preventing personal injury and goods damages, please carefully read and follow the contents marked with following symbols in this manual. For your convenience, in the following contents, the medical centrifuge is referred to as the centrifuge.

Safety label



Cautions

Grounding

Biological risks

	The upper and lower limits of temperature shall be indicated adjacent to the upper and lower horizontal lines.		Symbol for "Manufacture"
	Symbol for "Consult instructions for use"		Symbol for "Date of manufacture"
	European Authorized Representative	Elscolab BV. Tolboomweg 10, 3784 XC Terschuur, the Netherlands	

Safety Precautions



Check this manual in all cases marked with , so as to learn the nature of potential hazards and any countermeasures that must be taken.



Failure to comply with the items under warning signs may result in serious personal injury or even death.

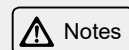

Failure to comply with the items under precaution signs may result in personal injury or damage to the centrifuge and related property damage.



Behaviors or actions that must be prohibited



Behaviors or actions that must be followed

Disclaimer

The following circumstances may affect the use of the equipment, the equipment user shall bear the resulting property losses or casualties:

- Failure to operate the equipment according to the operation manual
- Failure to use the equipment for the specified purpose
- Usage conditions with accessories and consumables not recommended by Haier
- Maintenance or repair of the equipment by personnel not authorized by Haier
- Unauthorized self-modification of equipment

- ! It is very important to read this instruction when using this machine for the very first time. Failure to use the equipment in the way specified in this manual may cause damage to the equipment;
- ! Only professional Haier technicians or after-sales service personnel authorized by Haier are allowed to install and maintain the centrifuge, otherwise may lead to electric shock or fire;
- ! Be sure to place the centrifuge firmly on a solid flat surface. If the centrifuge is not firmly fixed or placed in an appropriate place, it will cause the centrifuge to turn over or any personnel to be injured;
- ! Please connect the centrifuge with the dedicated power supply specified on the nameplate, otherwise it may cause fire or electric shock;
- ! If the voltage used is lower than 198V or higher than 264V, it is required to additionally provide an automatic voltage regulator, to ensure that the voltage meets the use requirements;
- ! If the power cord needs to be lengthened, the cross-sectional area of the extension part shall not be less than 1 mm² and the length shall not be longer than 3 m, otherwise may cause fire or electric shock;
- ⊘ Do not rely on the centrifuge.
- ! The power cable of this centrifuge is equipped with the three-wire (grounded) plug and conforms to the standard three-wire (grounded) socket of 10A. Under no circumstances can the ground pin of the power cord be cut or removed. Make sure the plug is plugged into the power outlet securely and reliably, otherwise fire may be caused;
- ! Please use power socket which has grounding wire, so as to prevent electric shock. If the socket is not grounding, the ground wire must be installed by a professional technician;
- ! In case of leakage of flammable gas such as coal gas, close the valve which has leakage, and open the doors and windows for ventilation. Do not plug in or out the power plug of the centrifuge, otherwise may cause explosion and fire;
- ! When disconnecting the plug of the centrifuge from power socket, hold the power plug firmly and do not pull lead of the power plug. Pulling the cable with hands may cause electric shock or fire due to short circuit;
- ! If the centrifuge does not operate normally, remove the power plug. Keeping the centrifuge operating in an abnormal state may cause electric shock or fire;
- ! Be sure to disconnect the power supply of the centrifuge before performing any repair or maintenance on it, so as to avoid electric shock or personal injury;
- ! Ensure that no foreign matters or suspended particles in or around the centrifuge are inhaled during maintenance. Otherwise, it may cause damage to your health;
- ! When the centrifuge is not in use for a long time, remove the power plug to prevent electric shock, electric leakage or fire due to aging of the plug cord;
- ! The scrapping disposal of the centrifuge shall be carried out by appropriate personnel;
- ! When restarting the centrifuge in case of any power failure or the power is off, it is necessary to check settings of the centrifuge. Change of settings may lead to changes of the results;
- ! Care should be taken not to trip over the centrifuge when handling it, in case the centrifuge is damaged or personnel are injured;
- ! Make sure no obstructions around the centrifuge and keep good ventilation condition;

Specification • packing list

Machine specifications

Name of product	LX-185T100R
Dimensions (length × width × height) (mm)	680×420×330
Maximum speed (rpm)	18500
Maximum centrifugal force (×g)	30130
Speed accuracy (rpm)	±10
Temperature setting range (°C)	-20°C ~40°C
Machine noise (dB(A))	52dB(A)
Power supply	AC220-240V / 50/60 Hz
Total power (W)	1200
Weight (kg)	57
Production date/Expected service life	See box barcode/10 years

Note: The company lays emphasis on technological innovation. The product parameters are subject to change without notice.

Rotor specifications

Rotor No.	Rotor type	Rotor capacity (ml)	Maximum speed (r/min)	Maximum centrifugal force (×g)
1	Angle rotor	12×1.5 / 2	18500	26019
2	Angle rotor	24×1.5 / 2	17500	30130
3	Angle rotor	48×1.5 / 2	13000	19083
4	Angle rotor	12×5	16000	18090
5	Angle rotor	12×10	12500	16071
6	Angle rotor	8×15	12000	13200
7	Angle rotor	6×50	12000	15294
8	Angle rotor	6×50(conical tube)	12000	16421
Optional	Adapter	15-50	6/set	
9	Angle rotor	4×100	11000	13257
10	Angle rotor	12×8×0.2	12000	18516

Circuit diagram

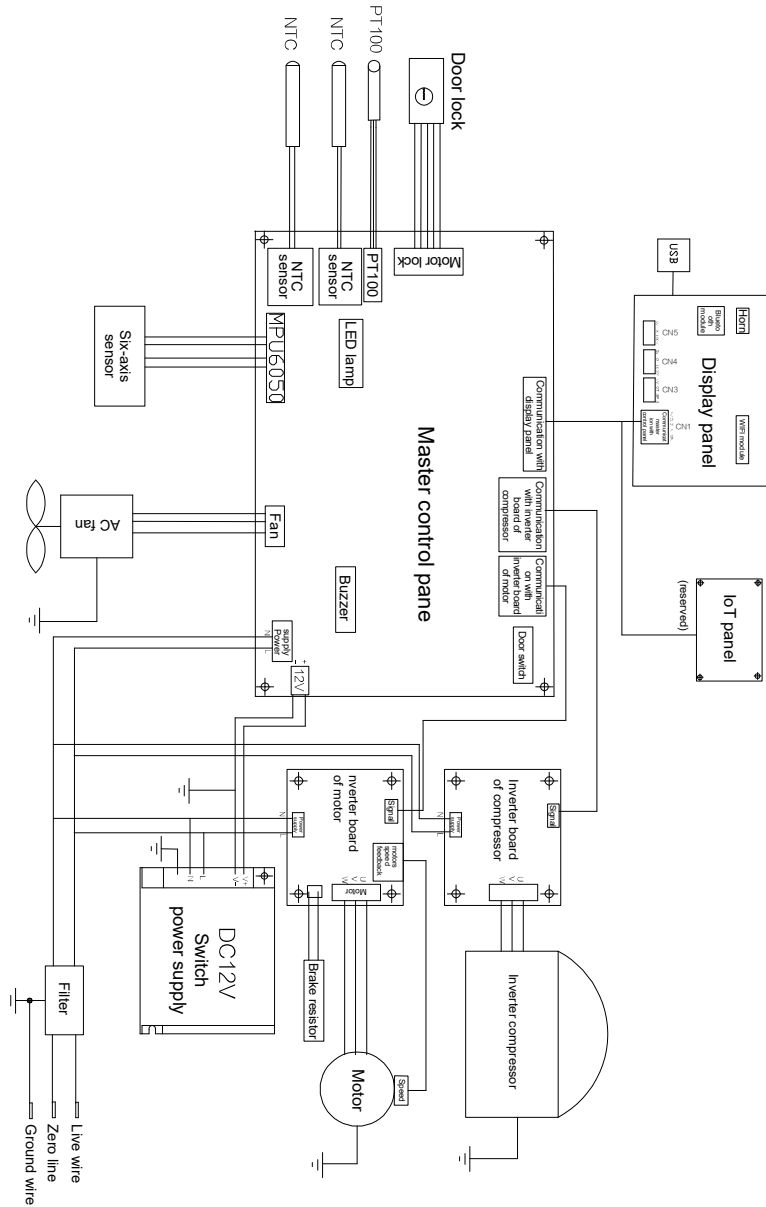

- ⊘ Do not place the centrifuge in a humid place or where may subject to splashing water. Otherwise, it may cause electric leakage or electric shock due to decreased insulation;
- ⊘ Do not pour water directly onto the centrifuge, otherwise may cause electric shock or short circuit;
- ⊘ Do not place any container with water or heavy objects on the centrifuge. If the object falls, it may cause personal injury, and the water flowing out may cause electric leakage or electric shock due to decreased insulation;
- ⊘ Do not touch electrical parts such as power plug or any switch with wet hands, otherwise it may cause electric shock;
- ⊘ Users are not allowed to disassemble, repair or modify the centrifuge by themselves. Otherwise, it may cause fire or personal injury due to improper operation;
- ⊘ Do not store inflammable or explosive dangerous goods or volatile goods in the centrifuge, or use flammable sprays near the centrifuge, otherwise, it may cause explosion or fire;
- ⊘ Do not insert metal objects such as nails or wires into any openings and gaps or any air vents for internal air circulation on the centrifuge, as this may result in electric shock or injury due to contact between above stated objects and moving parts.

Precautions for Use

Use restrictions



Danger! Explosion risk

- Do not operate this equipment indoors with explosive hazardous substances.
- Do not use the equipment to centrifuge explosive substances or highly active substances.
- Do not use the equipment to deal with substances that may produce explosive gases.



Warning! Do not use this equipment to separate the following substances

- Do not separate harmful substances.
- Do not separate toxic substances.
- Do not separate infectious liquids and pathogenic bacteria.



CAUTION

- Before using any cleaning or decontamination methods except those recommended by the manufacturer, users should check with the manufacturer that the proposed method will not damage the equipment.
- Observe the safety precautions and handling instructions for the cleaning agents used.



WARNING

- UV rays reduce the stability of plastics.
- Do not subject the centrifuge, rotors and plastic accessories to direct sunlight.

Danger caused by improper operation



Warning! Damage to equipment or power cord can lead to electric shocks

- Make sure the equipment and power cord are not damaged before starting the equipment.
- Only properly installed or maintained equipment can be started.
- Cut off the power supply of the equipment in case of danger. Unplug the power plug from the equipment or power outlet.



Warning! Lethal voltage in the equipment

- Contact with parts with high voltage may result in electric shock.
- Make sure the case is closed and no damage.
- Do not disassemble the case.
- Make sure no liquids enter the equipment.
- The equipment can only be disassembled by an authorized service organization.

Drainage device

The centrifuge is equipped with a built-in drainage device, which can transfer condensate water inside the centrifuge chamber into the water receiver on the left of the device, to avoid water accumulation in the centrifuge chamber. Check the water receiver regularly, and clear accumulated water in time.



Repair service

Haier suggests that authorized engineers carry out detection and maintenance of the centrifuge and its accessories once a year, to ensure the safe use and good experience of users. Detection items to be carried out are as follows:

1. Verify parameter performance of speed precision, timing precision, refrigeration effect, unbalance detection, etc.
2. Check electrical components, elements, and electrical parameters.
3. Check functions of safety devices such as door lock and horizontal state.
4. Check whether there are any abrasion, corrosion, crack, etc. on the rotor and its accessories.
5. Check whether there are abrasion and abnormal skip of the rotor and the drive shaft.
6. Check whether installation position and daily maintenance meet requirements.
7. Daily operation training.

Fault alarm treatment

Cleaning

Wipe the centrifuge with neutral solution or warm water. Corrosive detergents are prohibited, such as soap, bleach, detergent powder, etc. Remove intractable residues in the centrifuge chamber with a soft brush. Metal brush is prohibited, to avoid damage to the centrifuge chamber wall. Finally, wash it clearly with distilled water, and wipe it with a soft cloth. Turn the rotor upside down to dry.

Disinfection and sterilization

Any infectious materials splashing from the centrifuge during operation, disinfection should be performed immediately. Spray neutral detergent with a sprayer for cleaning, to ensure evenly spraying on all surface of the centrifuge chamber and the rotor.

The disinfection and sterilization flow of the rotor and its accessories:

1. Open the centrifuge cover.
2. Cut off the power supply of the centrifuge.
3. Unplug the power plug.
4. Unscrew the lock nut, hold the rotor with both hands and take it from the drive shaft.
5. Take out centrifugal tubes and adapter, and perform disinfection.
6. Spray detergent on the surface of the rotor with a sprayer, or soak the rotor.
7. Wipe off disinfectant and detergent on the rotor.
8. Wash the rotor and the rotor cover with water, and then turn them upside down to dry.
9. Dispose waste disinfectant according to correct methods.

Fuse

The power switch of the centrifuge is equipped with a built-in fuse, and the specification is: 10A 250V.



Warning! Chemical or mechanical damage to parts may cause injury

- Avoid mechanical damage to all parts.
- Check whether the parts are damaged before each use. Please replace the accessories in case of damage.
- Do not use accessories that exceed the maximum service life.



Caution! Wrong accessories can lead to safety hazards

- The use of accessories not recommended by Haier may affect the safety, normal function and accuracy of the equipment. Damage caused by improper use of accessories by users is not covered by Haier's warranty.



Centrifuging hazardous substances:

- Do not centrifuge explosive or flammable materials or substances which could react violently with one another.
- The centrifuge is neither inert nor protected against explosion. Never use the centrifuge in an explosion-prone environment.
- Do not centrifuge inflammable substances.
- Do not centrifuge toxic or radioactive materials or any pathogenic micro-organisms without suitable safety precautions.



Accidental spills can cause damage to equipment

- Switch off the equipment in time.
- Turn off the power supply.
- Clean equipment and machine parts carefully according to the instructions for cleaning and disinfection.



Condensed water can cause damage to electrical components

- Condensate may form inside the equipment after it is transported from a cooler environment to a warmer environment. Wait at least 4 hours after placing the equipment in place before connecting it to the power supply.



To avoid damage to equipment, remove the rotor when handling and transporting the centrifuge.



The equipment should be placed in a position easy to disconnect the power supply.

Incorrect operation of the centrifuge



- Damage may occur when colliding or moving the running equipment. The impact of the rotor on the wall of the centrifugal chamber can cause serious damage to the centrifuge or the rotor. Therefore, do not move or collide with the equipment while it is running.

Wrong use of rotor



Improper fixing of rotors and rotor covers may cause injury.

- Only after tightening the rotor and fastening the rotor cover can centrifugal separation be carried out.
- The improper fixing of the rotor and the rotor cover will cause abnormal sound of the centrifuge. Press immediately to end the centrifugal separation.



Asymmetric loading of rotors may cause injury

- The same centrifugal tubes shall be loaded symmetrically in the rotor.
- Weigh the centrifuge tubes using an electronic scale to check whether the load is symmetrical.



Overloading of the rotor may cause injury

- When the maximum speed and the maximum capacity or carrying capacity are reached, the density of the reagent to be centrifugally separated shall not exceed 1.2 g/mL.



Rotor cover damaged due to chemicals may cause injuries.

- If the rotor cover touches organic solvent, please clean it immediately.
- Regularly check the rotor cover for damage and cracks.
- If the rotor cover appears in a crack or becomes milky, please replace it immediately.



Corrosive chemicals will damage the rotor.

- Corrosive chemicals may affect the stability of the rotor.
- Keep the rotor away from corrosive chemicals, mainly including: alkali, strong acids, solutions containing heavy metal ions (Hg^{2+} , Cu^{2+} , etc.), organic halides, concentrated salt solution, and phenol.
- If the rotor is contaminated by corrosive chemicals, please clean it with neutral detergent in time. Put emphasis on cleaning the groove of the rotor.



Improper operation may cause the falling of the rotor.

- When taking and placing the rotor, be sure to hold the rotor with both hands to avoid falling.

Sequence No.	Fault name	Possible cause	Solutions
15	Abnormal door lock	Fault of door lock or sensor	Please turn off the power supply and then restart, or contact after-sales service personnel
16	Fault of temperature sensor at the exhaust port of compressor	Damaged sensor or circuit	Replace it, or contact after-sales service personnel
17	Fault of condensation temperature sensor	Damaged sensor or circuit	Replace it, or contact after-sales service personnel
18	Condensation high temperature alarm	Blocking or poor ventilation of condenser	Check and clean the condenser, or contact after-sales service personnel
19	High temperature alarm at the exhaust port of compressor	Too high temperature of the compressor or fault of refrigeration system	Please turn off the power supply for cooling and then restart, or contact after-sales service personnel

Fault alarm treatment

Causes of faults that may occur during operation and corresponding solutions:

Sequence No.	Fault name	Possible cause	Solutions
1	Over-voltage protection of drive module	Too high voltage	Please turn off the power supply and then restart
2	Over-current protection of drive module	Too large current	Please turn off the power supply and then restart
3	Output protection of drive module	Output error	Please turn off the power supply and then restart
4	No speed	Not started	Please turn off the power supply and then restart
5	Over-speed operation	The speed exceeds the set value	Please stop the device and then restart
6	Abnormal communication of control module	Abnormal circuit or signal	Please turn off the power supply and then restart, or contact after-sales service personnel
7	Abnormal communication of drive board	Abnormal circuit or signal	Please turn off the power supply and then restart, or contact after-sales service personnel
8	Abnormal communication of posture sensor	Abnormal circuit or signal	Please turn off the power supply and then restart, or contact after-sales service personnel
9	Abnormal communication of RFID	Abnormal circuit or signal	Please turn off the power supply and then restart, or contact after-sales service personnel
10	Temperature sensor fault	Damaged sensor or circuit	Please turn off the power supply and then restart, or contact after-sales service personnel
11	Abnormal identification module	Damaged sensor or circuit	Please turn off the power supply and then restart, or contact after-sales service personnel
12	Abnormal input of rotor label	Fault of rotor chip	Please turn off the power supply and then restart, or contact after-sales service personnel
13	Unbalanced load	Uneven load placement	Check the load and then retry
14	Too high temperature inside the centrifuge chamber	The temperature inside the centrifuge chamber exceeds 50°C	Open the door cover for cooling, or check the refrigeration system

Improper use of centrifugal tubes



An overload of centrifugal tubes may cause injuries

- Pay attention to the load limit of centrifugal tubes.
- Choose centrifugal tubes specified by the manufacturer according to the centrifugal force to be reached.



Damage to centrifugal tubes may bring dangers

- Do not use damaged centrifugal tubes. Otherwise, it may cause damage to the device and accessories, as well as loss of samples. Please visually inspect whether there is any damage to all centrifugal tubes before use.



Uncovered centrifugal tubes will bring dangers

- Open centrifugal tube covers may break during centrifugation, causing damage to the rotor and the centrifuge. So, please cover all centrifugal tubes before centrifugation.



Organic solvents will damage plastic centrifugal tubes

- Organic solvents (such as phenol) will reduce the strength of centrifugal tubes, which may be damaged.

Product introduction

Product purpose and application scope

Application scope: LX-185T100R, i.e. Desktop High-speed Micro Refrigerated Centrifuge, is a device to separate components in a mixture of liquid and solid particles or a mixture of liquid and liquid by means of centrifugal force. It is usually used in serum separation, plasma separation, protein deposition, or urine sediment examination in medical tests. And it is widely applied to universities, biochemistry, health care, food safety, life science, agriculture and forestry science, animal husbandry science, biopharmaceutical, etc.



Structure composition: The centrifuge mainly consists of control system, centrifuge chamber, drive system, rotor, refrigeration system (for refrigerated centrifuge), and safety protection device.

Product features

The device is equipped with variable frequency control system, touch panel, brushless AC variable frequency motor for direct drive, and refrigeration compressor. Its features are as follows:

- With “5 min quick refrigeration”, “menu-type one-click centrifugation”, “7-inch panorama interaction screen” under intelligent interaction, the centrifuge brings users excellent and smooth experience, and creates a leading intelligent interaction quick refrigeration and centrifugation solution around the world.
- Its maximum speed is 16,500 rpm, its maximum centrifugal force 25,872g, and it is equipped with the most common angle rotor of 24*1.5/2.0 ml, which is enough to complete centrifugation steps of the most of common DNA/RNA purification kits.
- The 7-inch LCD screen can realize multi-point touch control, sensitive touch, fast response, and direct operation with gloves, which is more convenient.
- With unique throttle technology based on PID algorithm and high-performance dual-inverter refrigeration technology, the refrigeration system can realize 5 min quick refrigeration.
- With a height of 24 cm and an amplitude (under the maximum speed) of 0.005 mm, the whole machine is designed as ultra low center of gravity, running more stably.
- The whole machine can automatically monitor vibration, detect unbalance during operation, and check installation level, ensuring use safety.

Operation procedure

1. Press the power switch.
2. Press  to open the door cover, place the rotor on the motor spindle, and then screw the nut. Put balanced and weighed centrifugation test samples into the rotor, and centrifugal tubes must be put in a centrosymmetric mode.
3. Close the door cover, and check whether it is locked tightly.
4. Press keys on the screen to set parameters. Verify that parameters are set correctly, press “” to operate, and the window displays operation parameters.
5. After the operation time reaches the set time, the machine automatically stops centrifugation timing and starts to decelerate. The machine has two kinds of timing modes: timing after start, i.e. it starts timing after clicking the start key; timing after reaching a speed, i.e. it starts timing after reaching the set speed.
6. After the rotor stops rotating, press  to take out centrifugal tubes.
7. Turn off the switch of the centrifuge, and cut off the power supply.

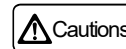

Cautions The operator must be on site during centrifugal separation.



Cautions When the centrifuge is powered off, repeatedly pull the pull string at the side (power interface side) of the centrifuge for at least 7 times to manually open the centrifuge cover.



Danger: It is prohibited to manually open the door cover during the operation of the rotor.

After centrifugal separation

1. Open the centrifuge cover, take out the angle rotor, and wipe off water inside the centrifuge chamber.
2. Turn off the switch of the centrifuge, and cut off the power supply.
3. Keep the centrifuge cover open to evaporate residual water.

Use and operation

Load the rotor

- Before use
 1. Check whether there are any break, scratch, and slight trace of corrosion on the rotor.
 2. Check whether the centrifuge chamber, drive shaft, and lock nut are damaged.
 3. Carefully rotate the rotor with hands, and check whether it can rotate freely.
 4. After putting test samples into centrifugal tubes, verify that the difference of their levels doesn't exceed 5 mm (permitted maximum level difference), put them into the rotor symmetrically, and close the rotor cover tightly.
 5. When a horizontal rotor is used, check whether the bucket is suspended reliably and whether the hangers get stuck.

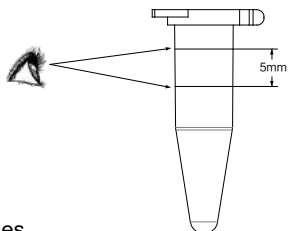

• Correct loading method of samples

Put test samples into centrifugal tubes, weigh them with an electronic balance, and ensure that the difference of their weights does not exceed 0.5 g (permitted maximum unbalance amount); unbalanced operation of the rotor is prohibited. Before starting the centrifuge, put centrifugal tubes (with the same model) in a centrosymmetric mode, do not exceed the permitted maximum unbalance amount, and then close the rotor cover tightly.

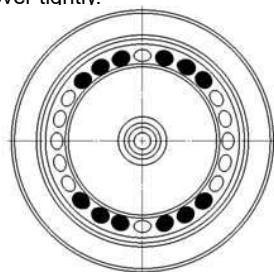

• Wrong loading method of samples



Designation and classification

- Designation: The specific designation rules are as follows:

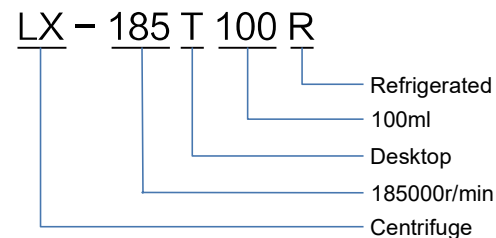

• Classification

It falls into Class I medical device according to the management classification of Medical Device Classification Catalog.

- a. It falls into Class 1 common device with protective grounding measures according to electric shock hazard protection.
- b. It falls into the desktop centrifuge according to structure
- c. It falls into the high-speed centrifuge according to speed
- d. It falls into the refrigerated centrifuge according to temperature

Due to product improvement, the Desktop High-speed Micro Refrigerated Centrifuge you received may not be completely consistent with the illustration of the instructions. We sincerely apologize for that. The contents of this manual are subject to change without notice.

Structural characteristics and working principle

Structure of the whole machine



- 1. Display/Operation interface.
- 2. Safety warning sign
- 3. Door lock staple
- 4. Door cover
- 5. USB interface
- 6. Pull string for manually opening cover
- 7. Transparent window
- 8. Power switch
- 9. Power outlet.
- 10. Nameplate.

Operating principle

By means of large centrifugal force generated by the high-speed rotation of the rotor in the centrifuge, the centrifuge accelerates the sedimentation velocity of particles in liquid, and then separates, condenses and purifies substances with different sedimentation coefficient and different buoyancy in samples.

Click  key, and then the help interface as shown in the figure below will display:



Reservation settings

Click  key, select "Reserve" to enter the reserve interface, and date, time, as well as temperature can be set. The centrifuge will start to refrigerate at set time.

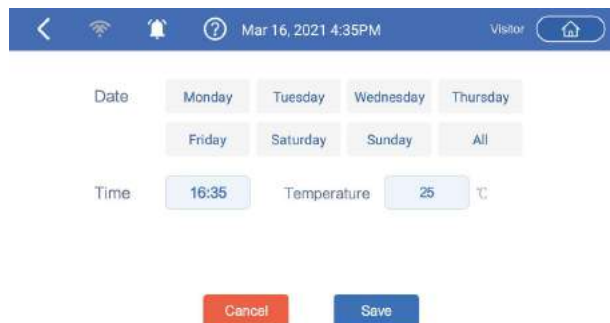

Information of the machine and help

Click  key to check the information of the machine and help. Press "About the machine" to display the information of the machine.



• Click  key, and then the screen will display the content of the PDF e-manual. Press Enter key to return to the previous level.

Installation and commissioning

Preparation before commissioning

• Unpacking

After receiving the goods, the user shall check the appearance of the packing box. There shall be no violent impact, lying, upside-down placement during transportation, etc., and the packing box shall be intact without damage. Please unpack it as per following steps:

- Open the outer packing box
- Take out accessories of the centrifuge and tools
- Take off objects surrounding the machine for protection during transportation
- Place the machine on suitable test bench or table

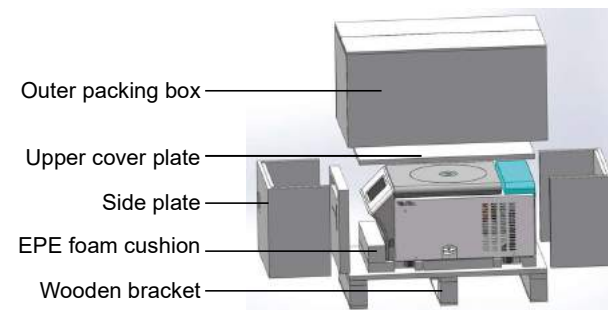

- When handling the centrifuge before unpacking, use a forklift or clamp truck.
- When using a clamp truck, clamp from the bottom of the bracket and only the side of the centrifuge can be clamped.
- When handling the centrifuge after unpacking, it is required to handle it by at least 2 people at the same time, and too large inclined angle of the centrifuge is prohibited.

• Check supplied accessories

Please check items in the box according to the contents of the packing list. If there is any discrepancy, please contact after-sales service personnel in time.

Installation requirements

• Installation environment

- Ambient temperature: In order to ensure the best use performance, the ambient temperature during the operation of the centrifuge shall be within 10°C~35°C. It is safe to use the centrifuge within 2°C~40°C.
- There shall be no relatively strong vibration source or high pressure around the centrifuge, a direct sunlight shall be avoided.
- Avoid mechanical shaking or vibration.
- Input voltage: AC220-240V

- e. Ambient humidity: below 80%Rh.
- f. The centrifuge shall operate at an altitude lower than 2000m.
- g. A safety zone of at least 30 cm must be maintained around the centrifuge.
People and hazardous substances must be kept out of the safety zone while centrifuging.
- h. Overvoltage category: The transient state is category II facility.
- i. Pollution Degree:2.

• Installation site

In order to ensure the centrifuge's normal operation and achieve the best performance, the installation site of the centrifuge shall meet the following conditions:

- a. Install it on a firm and horizontal indoor table top with good rigidity.
- b. There shall be no conductive dust or corrosive gas in the indoor air.
- c. After it is installed in place, the four rubber machine feet on the bottom board of it shall be stressed uniformly.
- d. The installation distance between the back of the machine and the wall as well as that between the side of the machine and the wall shall be no less than 30 cm, to meet the requirements of air cooling on air input and air output.
- e. Do not twist or stress the power cord.
- f. Please check the working voltage before use. For areas with unstable voltage, a voltage stabilizer that is suitable for motor load shall be adopted for voltage stabilizing, to ensure that the normal input voltage stabilizes in AC220-240V.
- g. There must be individual protective ground wire. Replacing it with zero line is prohibited.
- h. If the power socket is mounted with grounding wire, check whether the grounding condition is good before use.
- i. If the socket is not equipped with any grounding wire, which must be installed by a professional engineer technician.



Danger: To avoid electric shock, the protective ground wire shall be grounded reliably.



Fast program settings

After setting speed, time, temperature, etc., press and hold the symbol  or other figures for more than 3s, the screen will display the save page, input the name of centrifugation items, save it, and then the previous figure on the screen will be replaced by the name. If you press the corresponding figure or program name when setting parameters after starting the machine, stored program will be directly called to set speed, time, temperature, acceleration/deceleration parameters.

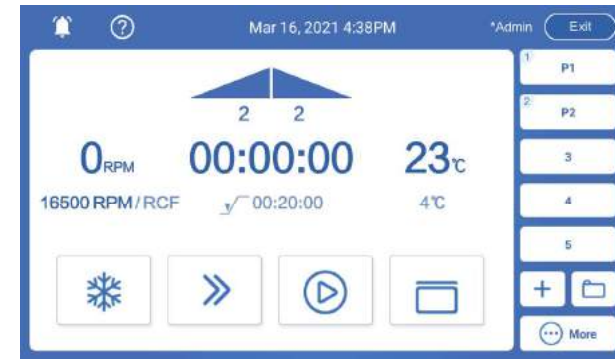

For example: fast program 1: Cell deposition, fast program 2: Protein purification.



Instantaneous centrifugation

Set the speed and temperature of instantaneous centrifugation first, and then press and hold the  key to start centrifugal separation. All other keys are invalid during instantaneous centrifugal separation. Release the  key to stop centrifugal separation.

Pre-cooling settings

Click  key, and the device starts running till the set temperature is reached. You can click  key at any time during the process to stop the pre-cooling mode.

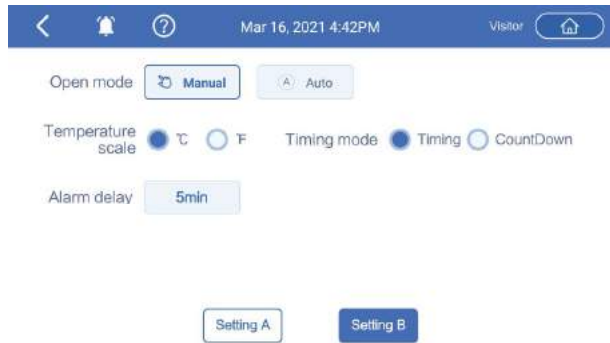

Commissioning requirements

- Check whether there is any damage to the device during transportation, and check accessories according to the packing list.
- Install the main machine, and turn on the power switch of it after verifying that everything is in good condition.
- Open the electronic gradiometer to detect the horizontal state of the machine, if the bubble of the electronic gradiometer shows green, it means the machine is horizontal; if the bubble shows red, adjust the experiment table or table till the electronic gradiometer bubbles shows green.

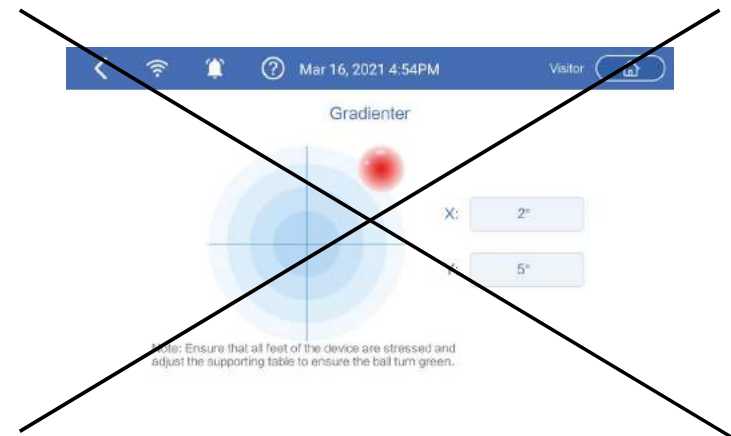



Level calibration was performed on the machine before leaving the factory, so it is not prohibited to regulate it during level regulation.

- Rotor installation: Press  to open the door cover. Place the rotor on the motor spindle, align the groove at the bottom of the rotor with the motor spindle pin, and then press it to the bottom. Hold the rotor with one hand to avoid its shaking, and rotate the lock nut clockwise with a wrench with the other hand till the rotor impact the motor spindle tightly.

Step 1:



Step 2:

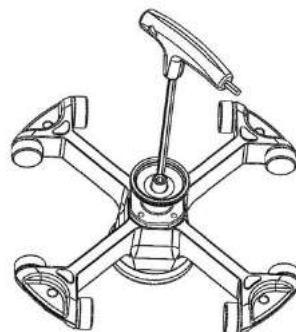

- Rotor removal (after centrifugation commissioning): Hold the rotor with one hand to avoid its shaking and rotate the lock nut anticlockwise with a wrench with the other hand till the rotor separates from the motor spindle. Hold the bottom of the rotor with both hands, and take the rotor from the centrifuge chamber upright and stably.



When installing and removing the motor, be sure to be gent and stable, to avoid damage to the drive shaft due to violence; before moving the machine, be sure to remove the rotor from the spindle, to avoid damage to the spindle.

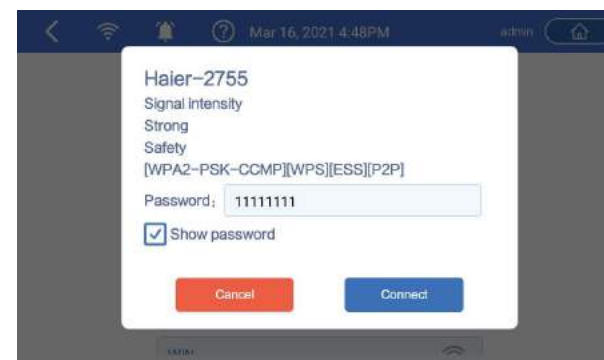

Basic settings and operation settings

Click  key, and select "Set" to enter the page of basic settings and operation settings.

- Time: Manually set the time in "Time adjustment";
- Language: Select a display language that you need in "Language selection";
- Alarm volume: Adjust the alarm volume;
- Brightness of touch screen: Adjust the brightness of touch screen;
- Screen sleep: Set the time of screen sleep;
- Energy-saving mode: Set the time of energy-saving mode;
- Open mode: Select manual or automatic as required;
- Set temperature scale: Set the temperature scale as °C or °F;
- Door open warning delay; Set the delay time of door open warning;
- Fault alarm delay; Set the delay time of fault alarm;

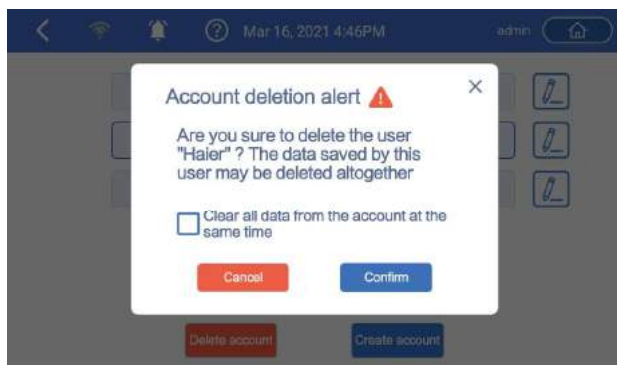

Network connection(WiFi feature is not available on the Overseas model)

Press “Network” key, and network connection, network disconnection, as well as network search will be displayed. After a name in machine network is selected, the screen will display the page for entering password. After entering the password, press “Connect”. After connecting the network, return to the previous interface, click “Save changes”, and then the selected network will work.

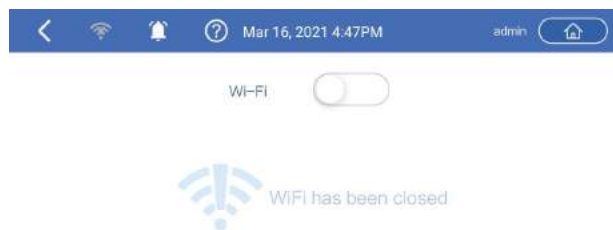

Description of operation function interface



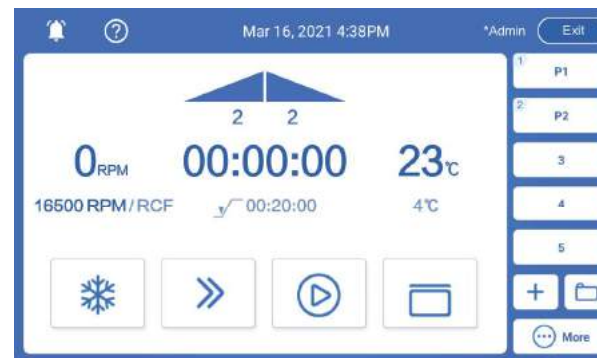

Function interface

After switching on the power supply, the interface of the main machine will display as shown in the figure below:

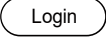

The functions of each key are as shown in the figure below:

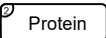
Key	Function
	Pre-cooling settings
	Instantaneous centrifugation operation (long press required)
	Start/Stop
	Open/Close status of the centrifuge cover
	Acceleration program value
	Deceleration program value
16500 _{RPM} 16500 RPM / RCF	Relative speed/Centrifugal force settings
00:20:00 √ 00:20:00	Time settings
4 ^{°C} 4 ^{°C}	Temperature settings
	Network connection
	Alarm information
2020-06-20 09:20	System time

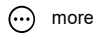
Key	Function
	User login
	Fast program settings
	
	Centrifugation program adding
	Centrifugation program library
	More operations

User login

Click  key to log in: Log in as an administrator for the first time, the account No. is: admin, and the password is: 8888888888.



Change password and create or delete new users

After the administrator logs in, click  key to enter the secondary interface, press "Account", and the screen will display logging information of the administrator. When the administrator logs in, the screen will display the page of password change immediately. After the password is changed, the screen will display the page of adding common user. Press "Add account", and a new account can be added. Data cleaning option box is supplied for the administrator to select.

