



Simply get your DR upgrade solution

Jumong Retro

SG Healthcare Jumong Retro



 **SGHealthCare**

1717SGC/SGG

User & Installation Manual
Service Manual

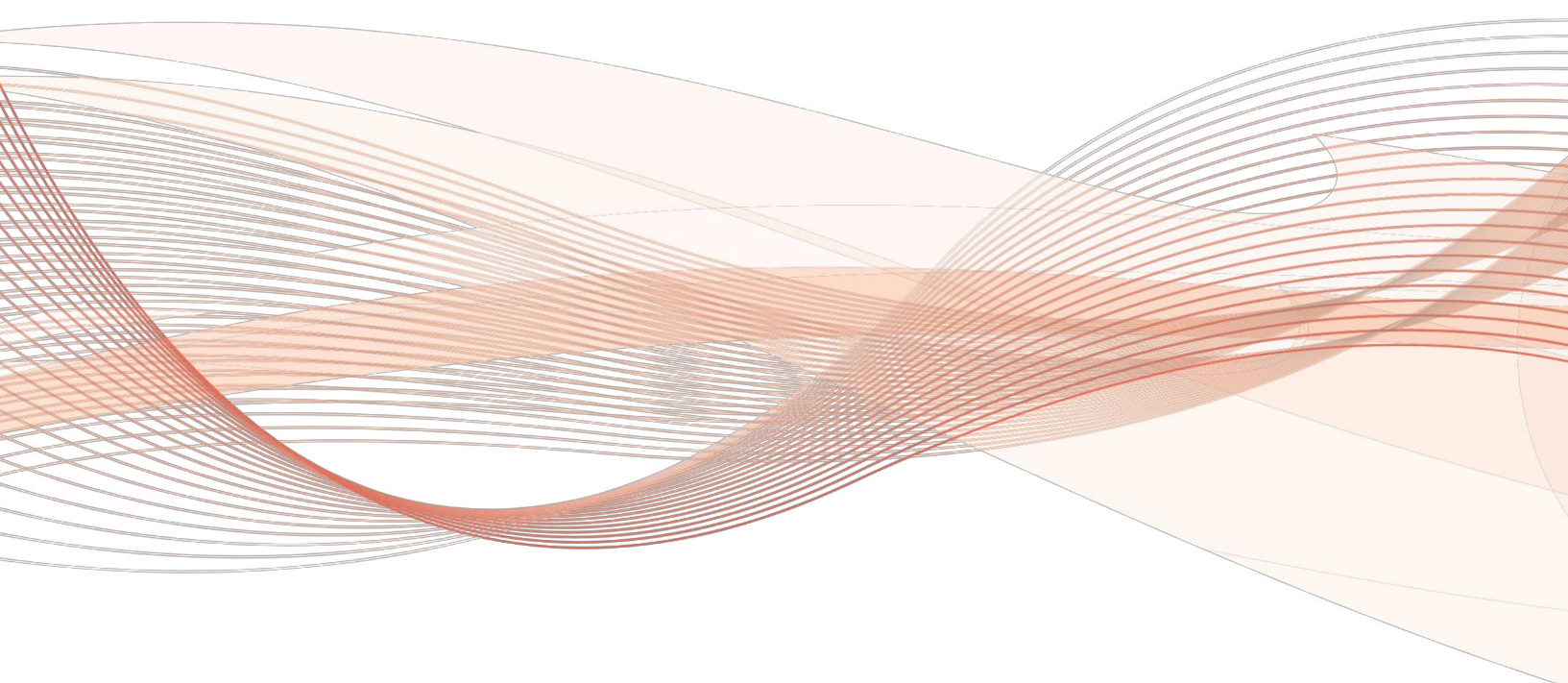
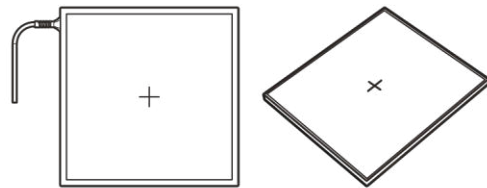

R-USM-009/010
Version: 3.0
Date: 2015-05-27

INDEX

Part.1 User & Installation Manual | 4 |

Part.2 Service Manual | 67 |

Part.1 User & Installation Manual

Please note that this information is for proper use and safety of the equipment. The following symbols may indicate a hazardous situation in which, if not heeded, may result in serious injury or even death to the user or others, or damage to the equipment.



Used to emphasize essential information.
Be sure to read this information to avoid incorrect operation.



Indicates warning and safety instructions. If not adhered to, it could result in death or serious injury to the user or others.



Indicates a hazardous situation which, if not heeded, may result in minor or moderate injury to the user or others, or damage to the equipment.

For users in the United States:

- United State federal law restricts this equipment to be used by or on the order of a physician.
- Since the X-ray exposure condition can be changed depending on the age, gender and bone density of the patient, in case of Pediatric, X-ray exposure condition can be changed by expert's judge. For further information, please refer to FDA Pediatric X-ray Imaging webpage.
<http://www.fda.gov/radiation-emittingproducts/radiationemittingproductsandprocedures/medicalimaging/ucm298899.htm>

For users in other countries:

- This equipment is to be used by or on the order of a licensed person under the related laws for each country.

Intended use:

This equipment provides digital X-ray imaging for diagnosis of disease, injury, or any applicable health problem.



VATECH Dental Manufacturing Ltd.

VATECH Dental Manufacturing Ltd.
Chancery House, St. Nicholas Way, Sutton, SM1 1JB, United Kingdom
Tel : +44 208 652 1990, Fax : +44 208 652 1909



SG HealthCare Co., Ltd.

753 ITECO, 150, Jojeong_Daero, Hanam-Si, Gyeonggi-do, Korea
www.sghealthcare.com

Contents

Ch.1

Safety Information

Ch.2

Product Introduction and Specifications

Ch.3

Installation and Calibration

1.Safety Standard	8	1.Product Features	24	1.Installation	32
2.Symbols	14	2.Product Components	25	2.Calibration	46
3.Warnings	16	3.Part Names and Functions	26		
4.Cautions	18	4.Part Specifications	28		
5.Safety Information	20	5.Environmental Requirements	30		
6.Label and Location of Attachment	23	6.Dimensions	31		

Ch.4

Usage

Ch.5

Maintenance

Ch.6

Warranty

1.Set Up	53	1.Cleaning	62	Warranty	65
2.Image Acquisition	55	2.Inspection	62		
3.View Images	57	3.Replaceable Parts and Instruction of Replace	63		
4.Additional Function	60	4.Disposal or Recycling	64		

Ch.1 Safety Information

1.Safety Standard

1 Medical Device Classification

Classification by protection type against Electric Shock	Class 1 equipment
--	-------------------

Classification according to the degree of protection against ingress of water	IPX0
---	------

Mode of operation	Continuous Operation
-------------------	----------------------

Environment of Use	This equipment is not suitable for use in the presence of flammable anesthetic or oxygen.
--------------------	---

2 Regulations

1. Safety and Electromagnetic Compatibility Information

IEC/EN/UL 60601-1	Medical electrical equipment Part 1: General requirements for safety
-------------------	---

IEC/EN 60601-1-2	Medical electrical equipment Part 2: Electromagnetic compatibility-requirements and tests
------------------	--

This equipment has been tested and found to comply with the limits for medical devices in IEC 60601-1-2. These limits are designed to provide reasonable protection against harmful interference in a typical medical installation.

This equipment generates, uses and can radiate radio frequency energy. If not installed and used in accordance with the instructions, it may cause harmful interference to other devices in the vicinity. However, there is no guarantee that interference will not occur in a particular installation. If this equipment does cause harmful interference to other devices, which can be determined by turning the equipment off and on, the user is encouraged to try to correct the interference by one or more of the following measures.

- Reorient or relocate the equipment.
- Increase the separation between the equipment.
- Connect the equipment into an outlet on a circuit different from that to which the other devices are connected.
- Contact SG HealthCare Customer Service team or authorized agent for help.

In addition, all systems shall comply with the standard IEC 60601-1 and/or IEC 60601-1 harmonized national standard or both. If in doubt, contact SG HealthCare Customer Service team or authorized agent.

2. Electro-Magnetic Compatibility Information

[Electro-Magnetic Emissions]

This EUT is intended for use in the electromagnetic environment specified below.
The customer or the user of the EUT should assure that it is used in such an environment.

Immunity Test	Compliance	Electromagnetic Environment – Guidance
RF Emissions CISPR 11	Group 1	The EUT uses RF energy only for its internal function. Therefore, its RF emissions are very low and are not likely to cause any interference in nearby electronic equipment.
RF Emissions CISPR 11	Class A	The EUT is suitable for use in all establishments, including domestic establishments and those directly connected to the public low-voltage power supply network that supplies
Harmonic emissions IEC 61000-3-2	A	buildings used for domestic purposes.
Voltage fluctuations/ Flicker emissions IEC 61000-3-3	Complies	

[Electro-Magnetic Immunity]

This EUT is intended for use in the electromagnetic environment specified below. The customer or the user of the EUT should assure that it is used in such an environment

Immunity Test	IEC 60601-1-2 Test Level	Compliance Level	Electromagnetic environment – guidance
Electrostatic discharge (ESD) IEC 61000-4-2	±6 kV Contact ±8 kV Air	±6 kV Contact ±8 kV AIR	Floors should be wood, concrete or ceramic tile. If floors are covered with synthetic material, the relative humidity should be at least 30%
Electrical fast transient/burst IEC 61000-4-4	±2 kV for power supply lines ± 1 kV for input/output lines	±2 kV for power supply lines ± 1 kV for input/output lines	Mains power quality should be that of a typical commercial or hospital environment.
Surge IEC 61000-4-5	±1 kV differential mode ±2 kV common mode	±1 kV differential mode ±2 kV common mode	Mains power quality should be that of a typical commercial or hospital environment.
Voltage dips, short interruptions and voltage variations on power supply input lines) IEC 61000-4-11	<5% UT (>95% dip in UT for 0.5 cycle). 40% UT (60% dip in UT for 5 cycle) 70% UT (30% dip in UT for 25cycle) <5% UT (<95% dip in UT) for 5s	<5% UT (>95% dip in UT for 0.5 cycle). 40% UT (60% dip in UT for 5 cycle) 70% UT (30% dip in UT for 25cycle) <5% UT (<95% dip in UT) for 5s	Mains power quality should be that of a typical commercial or hospital environment. If the user of the EUT image intensifier requires continued operation during power mains interruptions, it is recommended that the EUT image intensifier be powered from an uninterruptible power supply.
Power frequency (50/60Hz) magnetic field) IEC 61000-4-8	3 A/m	3 A/m	Power frequency magnetic fields should be at levels characteristic of a typical location in a typical commercial or hospital environment.

NOTE : UT is THE A.C mains voltage prior to application of the test level.

Immunity Test	IEC 60601-1-2 Test Level	Compliance Level	Electromagnetic environment – guidance
Conducted RF IEC 61000-4-6	3 Vrms 150 kHz to 80MHz	3 Vrms 150 kHz to 80MHz	Portable and mobile RF communications equipment should be used no closer to any part of the EUT, including cables, than the recommended separation distance calculated from the equation applicable to the frequency of the transmitter.
Radiated RF IEC 61000-4-3	3 V/m 80 MHz to 2.5GHz	E1=3V/m	

Recommended separation distance :

$$d = \left[\frac{3,5}{V_1} \right] \sqrt{P}$$

$$80 \text{ MHz to } 800 \text{ MHz} \quad d = \left[\frac{3,5}{E_1} \right] \sqrt{P}$$

$$800 \text{ MHz to } 2.5 \text{ GHz} \quad d = \left[\frac{7}{E_1} \right] \sqrt{P}$$

Where P is the maximum output power rating of the transmitter in watts(W) according to the transmitter manufacturer and d is the recommended separation distance in meters(M).

Field strengths from fixed RF transmitters as determined by an electromagnetic site survey, should be less than the compliance level in each frequency range.

Interference may occur in the vicinity of equipment marked with the following symbol :



NOTE 1) At 80MHz and 800MHz, the higher frequency range applies.

NOTE 2) These guidelines may not apply in all situations. Electromagnetic propagation is affected by absorption and reflection from structures, objects and people.

Field strengths from fixed transmitters, such as base stations for radio (cellular/cordless) telephones and land mobile radios, amateur radio, AM and FM radio broadcast and TV broadcast cannot be predicted theoretically with accuracy.

To assess the electromagnetic environment due to fixed RF transmitters, an electromagnetic site survey should be considered. If the measured field strength in the location in which the EUT is used exceeds the applicable RF compliance level above, the EUT should be observed to verify normal operation.

If abnormal performance is observed, additional measures may be necessary, such as re-orienting or relocating the EUT. b Over the frequency range 150 kHz to 80 MHz, field strengths should be less than [V1] V/m.

[Recommended separation distance between portable and mobile RF communications equipment and the EUT]

There is intended for use in an electromagnetic environment in which radiated RF disturbances are controlled. The user of the EUT can help prevent electromagnetic interference by maintaining a minimum distance between portable and mobile RF communications equipment (transmitters) and the EUT as recommended below, according to the maximum output power of the communications equipment.

Separation distance according to frequency of transmitter [m] IEC 60601-1-2

Frequency of Transmitter	150kHz to 80MHz	80MHz to 800MHz	800MHz to 2.5GHz
Equation	$d = \left[\frac{3,5}{V_1} \right] \sqrt{P}$	$d = \left[\frac{3,5}{E_1} \right] \sqrt{P}$	$d = \left[\frac{7}{E_1} \right] \sqrt{P}$
Rated maximum output power of transmitter [W]	V1=3Vrms Separation Distance (meters)	E1=3V/m Separation Distance (meters)	E1=3V/m Separation Distance (meters)
0.01	0.116	0.1166	0.2333
0.1	0.368	0.3687	0.7378
1	1.166	1.1660	2.3333
10	3.687	3.6872	7.3785
100	11.660	11.6600	23.333











For transmitters rated at a maximum output power not listed above, the recommended separation distance d in meters (m) can be estimated using the equation applicable to the frequency of the transmitter, where p is the maximum output power rating of the transmitter in watts (W) according to the transmitter manufacturer.









NOTE 1) At 80 MHz and 800 MHz, the separation distance for the higher frequency range applies.

NOTE 2) These guidelines may not apply in all situations. Electromagnetic propagation is affected by absorption and reflection from structures, objects and people.

a Field strengths from fixed transmitters, such as base stations for radio (cellular/cordless) telephones and land mobile radios, amateur radio, AM and FM radio broadcast and TV broadcast cannot be predicted theoretically with accuracy. To assess the electromagnetic environment due to fixed RF transmitters, an electromagnetic site survey should be considered. If the measured field strength in the location in which the EUT is used exceeds the applicable RF compliance level above, the EUT should be observed to verify normal operation. If abnormal performance is observed, additional measures may be necessary, such as re-orienting or relocating the EUT. b Over the frequency range 150 kHz to 80 MHz, field strengths should be less than [V1] V/m

2.Symbols

Symbols	Descriptions
	Refer to instruction manual/ booklet
	Alternate current
	Protective earth (Ground)
	Off (power : disconnect from the main switch)
	On (power : connect from the main switch)
	On / Off (button type)
	Warning
	Caution
	Read carefully
	Manufacturer
	Date of manufacture

Symbols	Descriptions
	Serial number
	Non-ionizing radiation
	WEEE : Waste Electrical and Electronic Equipment
CE0120	CE symbol grants the product compliance to the European Directive for Medical Devices 93/42/EEC as a class IIb device and 1999/5/EC. Authorized by Notified Body SGS (code no.:0120) of British
	Authorized representative in the European community.
	Keep dry
	Fragile, handle with care
	This side up
	4 layer stacking
	Temperature limit

3. Warning

WARNING



Environment of Use and Storage

WARNING Follow the specified process of operational instructions written in this manual for the safety of the users and patients.

Do not use or store the detector near any flammable chemicals such as thinner, benzene, etc. Also, this detector is not a category AP or APG equipment. If chemicals are spilled or evaporate, it may result in fire or electric shock through contact with electric parts inside the detector. Also, some disinfectants are flammable. Be sure to take care when using them.



WARNING

Connection

Do not connect the detector with anything other than specified. Otherwise, it may result in fire or electric shock.

To avoid the risk of electric shock, this detector must only be connected to supply mains with protective earth.



WARNING

Handling

Always be sure to keep checking the condition of the system and the patient to ensure they are normal during the use of the detector. If any problem is found, take appropriate measures, such as stopping the operation of the detector, as required.

Never disassemble or modify the detector as it may result in fire or electric shock. Also, since the detector incorporates parts that may cause electric shocks and other hazardous parts, touching them may cause death or serious injury.

Do not hit or drop the detector. The detector may be damaged if it receives a strong jolt, which may result in fire or electric shock if the detector is used without being repaired.



WARNING

When Problem Occurs

Should any of the following occur, immediately turn OFF the power of each detector, unplug the power supply cord from the AC outlet, and contact SG HealthCare Customer Service team or authorized agent.

- When there is smoke, odd smell or abnormal sound.
- When liquid has been spilled into the detector or a metal object has entered through an opening.
- When the detector has been dropped and it is damaged.



WARNING

Maintenance and Inspection

For safety reasons, be sure to turn off the power of the detector when the following inspections are going to be performed. Otherwise, it may result in electric shock.

When the detector is going to be cleaned, be sure to turn off the power of each detector, and unplug the power cable from the AC outlet.

Do not use any type of solvent, such as benzene. Otherwise, fire or electric shock may result.

Wear waterproof gloves to protect your hands from direct contact with IPA (Isopropyl alcohol) or any other liquid.

Maintenance of the detector should be done by an authorized service provider. If problem still cannot be corrected, it may result in fire or electric shock

4 Caution



CAUTION

Environment of Use and Storage

Do not install the detector in a location with the conditions listed below. Otherwise, it may result in failure or malfunction, cause fire or injury.

- Close to facilities where water is used.
- Where it will be exposed to direct sunlight.
- Close to air-conditioner or ventilation equipment.
- Close to heat source such as a heater. • Prone to vibration
- Insecure place.
- Dusty environment.
- Saline or sulfurous environment.
- High temperature or humidity.
- Freezing or condensation.

Do not place the storage case in a location with the conditions listed below.

- Where the cable of the detector unit will be strongly pulled when the detector is put into the case, otherwise, the cable may be damaged, resulting in fire or electric shock.
- Where someone might get their foot caught in the cable of the detector.

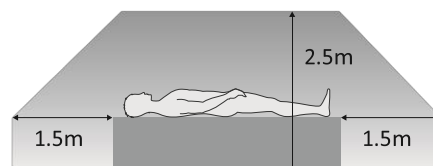
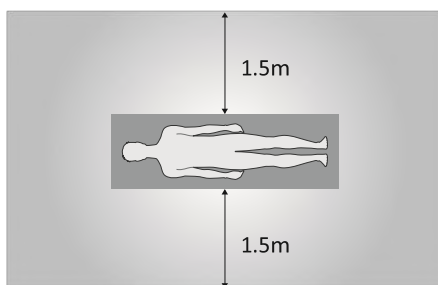



Handling

In order to prevent infection, please wipe the CFRP(Carbon Fiber Reinforced Plastic) with a soft cloth moistened with IPA (Isopropyl-alcohol) liquid.

CAUTION

Wear waterproof gloves to protect your hands from direct contact with IPA or any other liquid.

For safety reasons, be sure to turn off the power of each equipment when detector is not used.

This detector is contraindicated for pregnant woman.

If contact over 24 hours on CFRP(Carbon Fiber Reinforced Plastic) of detector, it could be cause skin irritation.



Location of Cables

CAUTION

Make sure all cables are located so that they cannot be stepped on, tripped over, or otherwise subjected to damage or stress.



Maintenance and Inspection

CAUTION

For safety reasons, be sure to inspect the detector before using it. In addition, carry out a regular inspection at least once a year.

If the detector is defective, do not disassemble the detector randomly. Maintenance of the detector should be done by an authorized service provider. Please contact SG HealthCare Customer Service team or authorized agent.

Be sure to check the user's manual for replaceable components.



Modifications

CAUTION

Any changes or modifications in construction of this detector which are not expressly approved by the party responsible for compliance could void the user's authority to operate the detector.

5 Safety Information

[Preparation]

- Be sure to connect the cables to the proper connectors. Otherwise, the detector may malfunction or may be damaged.
- The power supply provided by SG HealthCare is designed for the detector from SG HealthCare. Please contact SG HealthCare, if any other type of power supply is needed to be used.

[Handling]

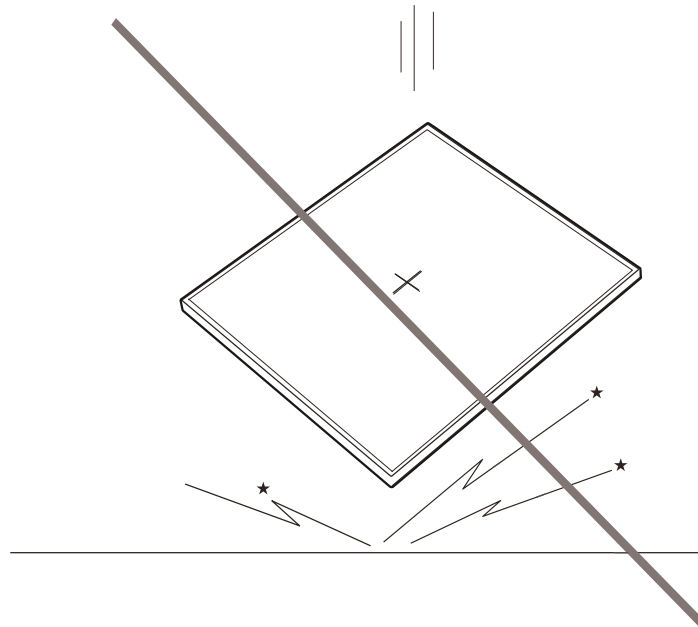

- Handle the detector carefully, as it may become damaged if it is hit, dropped, or receives a strong jolt.

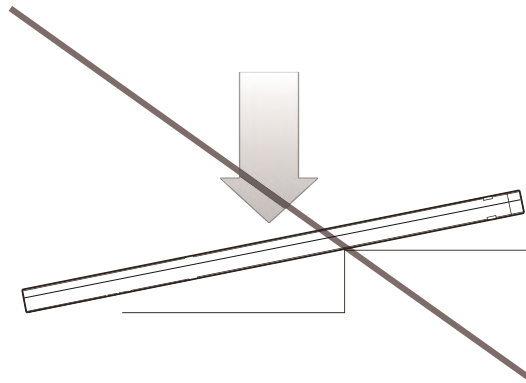

- Be sure to use the detector on a flat place so it will not bend. Otherwise, the detector may be damaged.
- Be sure to check the detector daily and confirm that it works properly. Sudden heating of the room in cold areas will cause condensation to form on the detector. In this case, wait until condensation disappears before performing exposure. If the detector is used with condensation formed on it, problems may occur in the quality of the detector. When an air-conditioner is going to be used, be sure to raise/lower the temperature gradually so that a difference in temperature in the room and in the detector does not occur, to prevent forming of condensation. Follow the recommended proper Room temp.
- Do not use the detector near devices generating a strong magnetic field. Doing so may produce image noise or artifacts.
- Keep the connectors free from being in contact with the patient.
- Connectors are intended to be connected to an external device and must follow IEC standards.

- Do not apply excessive weight to the detector. Otherwise, the detector may be damaged.

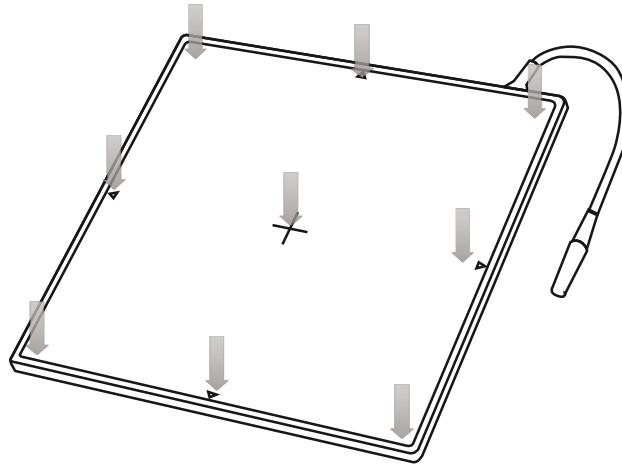

Overall Pressure: 150kg over the whole area of detector window.

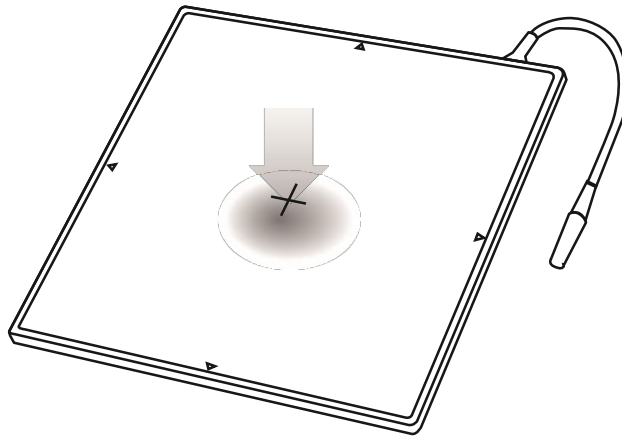

Partial Pressure: 100kg on an area 40 mm in diameter.

[Disinfection and Cleaning]

- Do not spray disinfectants or detergents on the detector.
- When cleaning the detector, be sure to turn off the power, and unplug the power cable from the AC outlet.
- Do not use any flammable chemicals such as thinner, benzene for cleaning. Otherwise, fire or electric shock may result.
- Wear waterproof gloves to protect your hands from direct contact with disinfectants or detergents.

6 Label and Location of Attachment

Refer to the back of the device for details.

Ch.2 Product Introduction and Specification

1 Product Features

The 1717SGC/SGG are digital flat panel detectors that have been designed for a faster, more streamlined approach to digital radiography systems.

By having the same 15 mm thickness as traditional film screen cassettes, this lightweight detector fits into existing standard cassette trays, allowing existing film or CR systems to be easily upgraded.

The 1717SGC/SGG detectors utilize a combination of propriety TFT glass and high quality scintillators, which along with a pixel pitch of 127 microns and 3.9 lp/mm of resolution, assures delivery of sharp, high quality images.

Through our Gigabit Ethernet interface, images can be viewed in as little as 2 seconds. It uses auto trigger signal sensing technology that does not require any integration into an X-ray generator.

The 1717SGC/SGG are economical digital solution designed to meet your radiology department requirements.

2 Product Components

1 Basic Components

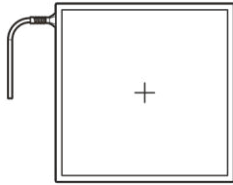

Detector 1EA



Power Supply 1EA



AC power cord 1EA
(110V or 220V, 1.8m)

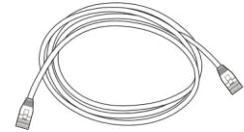

LAN Cable 1EA
(CAT 6(direct), 10m)



Link Cable 1EA
(7m)



Installation CD 1EA

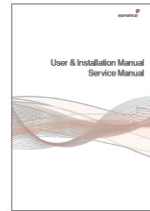

Manual 1EA

2 Optional Components



Trigger Cable 1EA

3 Part Name and Function

1 Detector

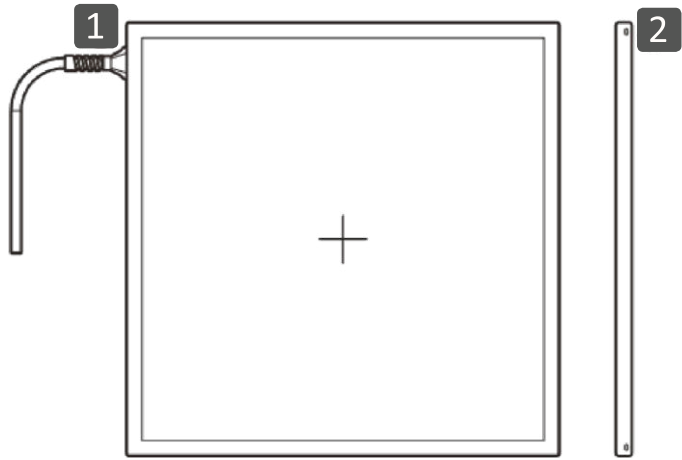

1 Link Cable

Use for power supplying and data communication.
Connect between detector and power supply

2 Shock Sensor

The sensor detects and records impact and mishandling of fragile

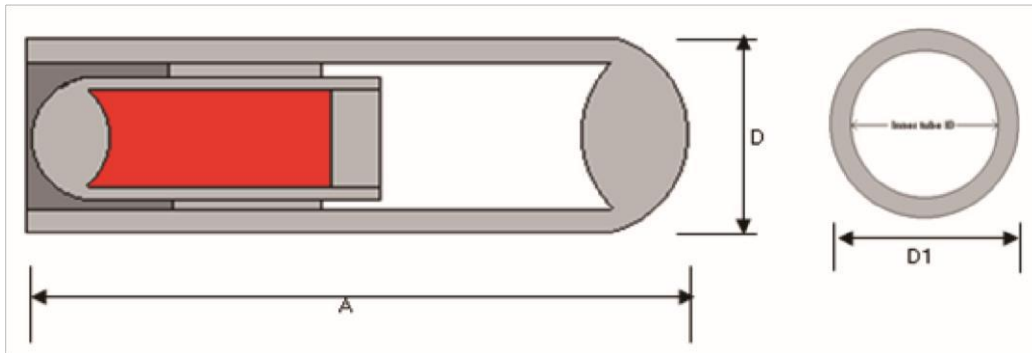

Type	A LENGTH	D(D1) DIAMETER OF OUTER TUBE
CLIP_CX 35	17.145±0.25	2.387±0.05

3 Power Supply

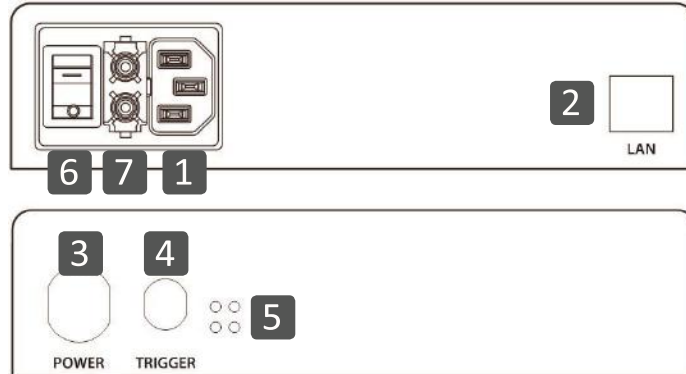

- 1 Power Plug Connector Connects to the AC power cord
- 2 LAN Connector Ethernet port for transmitting an image/command between the detector and PC
- 3 Link Connector Connects link cable to the detector for operating
- 4 Trigger Connector Connects trigger cable to the generator
- 5 LED Indicator Displays status of the power supply

Color	Status	Power Status
Green	On	Power on
- 6 Switch Power On/Off switch
- 7 Fuse T3.15 AL 250V

4 Parts Specifications

1 Detector

Parameter	Spec.	Unit
Sensor Type	Amorphous Silicon with TFT (Single panel)	-
Scintillator Type	1717SGC – Gd ₂ O ₂ S:Tb 1717SGG – CsI:Tl	-
Total Pixel Matrix	3328 X 3328	Pixels
Total Pixel Area	422.7 X 422.7	mm
Pixel Pitch	127	μm
Effective Pixel Matrix	3268 X 3268	Pixels
A/D Conversion	14 / 16	bits
Data Transfer	Ethernet 1 Gbps	-
Preview time	≤2	sec
Energy range	40 ~ 150	kVp
MTF (@1lp/mm)	1717SGC – Min. 50 / Typ. 57 1717SGG – Min. 50 / Typ. 59	%
DQE (@0.1lp/mm)	1717SGC – Min. 36 / Typ. 45 1717SGG – Min. 50 / Typ. 65	%
Defective lines	≤10	Lines
Defective pixels	≤22000	Pixels
Dimension	460 X 460 X 15.5	mm
Weight	4.0	Kg

Parameter	Spec.	Unit
Window material	Carbon fiber	-
Trigger mode	Manual Mode Auto Trigger Mode (Auto Exposure Detection)	-
Power consumption	18	W

2 Power Supply

Parameter	Spec.	Unit
Dimension	188 X 92 X 41.5	mm
Weight	0.5	kg
Input rate	100-240VAC (50/60Hz)	-
Output	Typ. 24VDC (Max 1.9A)	-

3 Cable

Item	Length	Unit	Qty.
Link cable	7	m	1
LAN cable (CAT 6(direct))	10	m	1
Power cord (110V or 220V)	1.8	m	1
Trigger cable (Optional)	10	m	1

5 Environmental Requirement

1 PC Requirement

CPU	<ul style="list-style-type: none"> At least Intel Pentium IV HT with 2.8GHz, Intel Core Duo / Core 2 or comparable AMD Dual Core processor
RAM	<ul style="list-style-type: none"> At least 3GB of RAM requirement (4GB for 32 BITS OS and 8GB for 64 BITS OS recommended)
Capacity of Disk Drive	<ul style="list-style-type: none"> At least 500GB for application and archiving. Recommended 500GB for applications and secondary drive of 1TB for image archiving.
Network Card	<ul style="list-style-type: none"> Dual 10/100/1000 network card system required. One for network (Internet) and one for the DR Panel communication
Graphic Card / Monitor	<ul style="list-style-type: none"> Graphics card / monitor: Resolution of at least 1,600 x 900 for desktop and 1366 x 768 for laptop. For diagnostics purpose we recommend 1920 x 1080 resolution (2 mega pixels) monitor
Operating System(OS)	<ul style="list-style-type: none"> Microsoft® Windows XP/VISTA/7 32BIT/64BIT
ETC	<ul style="list-style-type: none"> No antivirus except for Microsoft® Security Essentials.

2 Environmental Requirement

Environment	Min.	Typ.	Max.	Unit	Note
Temperature(Storage)	-10		50	°	
Temperature(Operation)	5		40	°	
Humidity(Storage)	10		80	% H.R.	
Humidity(Operation)	30		75	% H.R.	

3 Grid Requirement

Item	Description
SID	100/130/180
Ratio	8:1
Frequency	230 Line/inch

Dimensions

(Unit: mm)

1 Detector

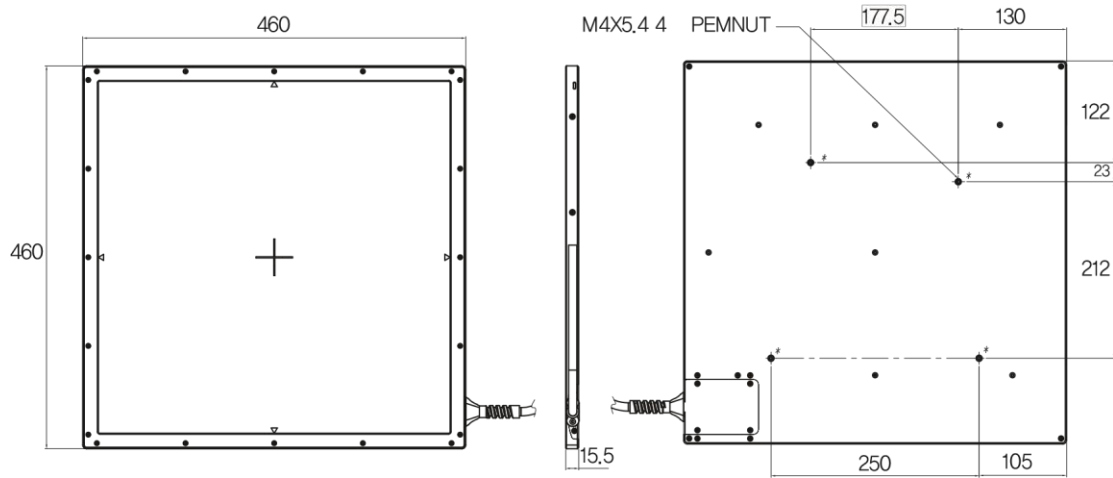

2 Power Supply

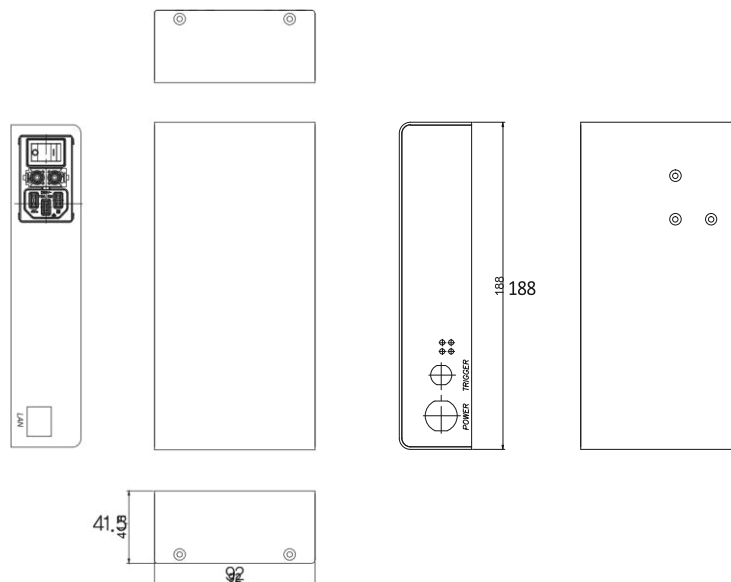

Ch.3 Installation and Calibration

1 Installation

1 Software Installation

- ① Insert the CD that comes with the Detector
- ② Install "setup.exe" from "\Release Davinci_version" and click "Next"

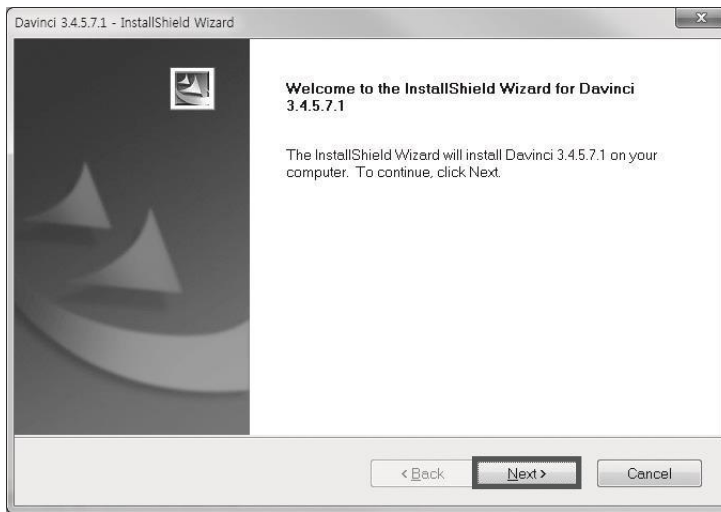

- ③ For the 1717SGC model select 1717SGC-R, and for the 1717SGC, select 1717SGC-R. Click "Next"

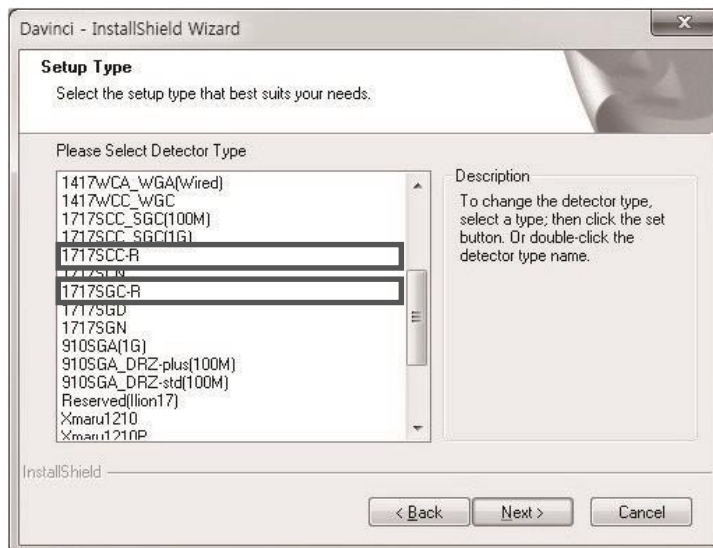

④ Click “Next”

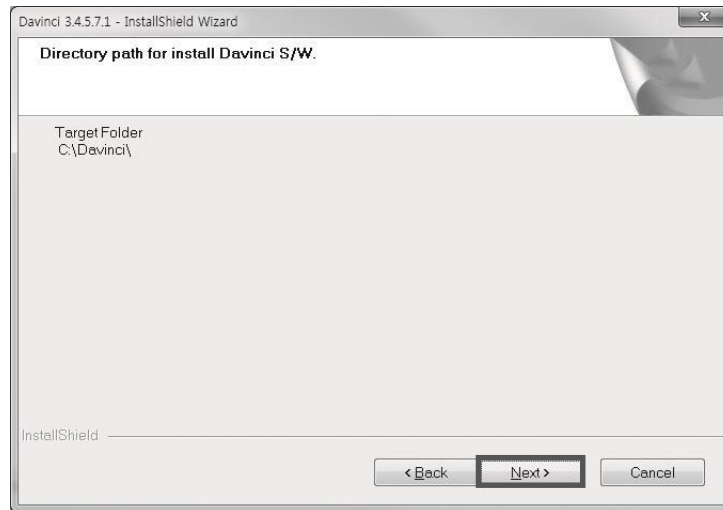

⑤ Select “MultiByte-Character Set” and click “Next”

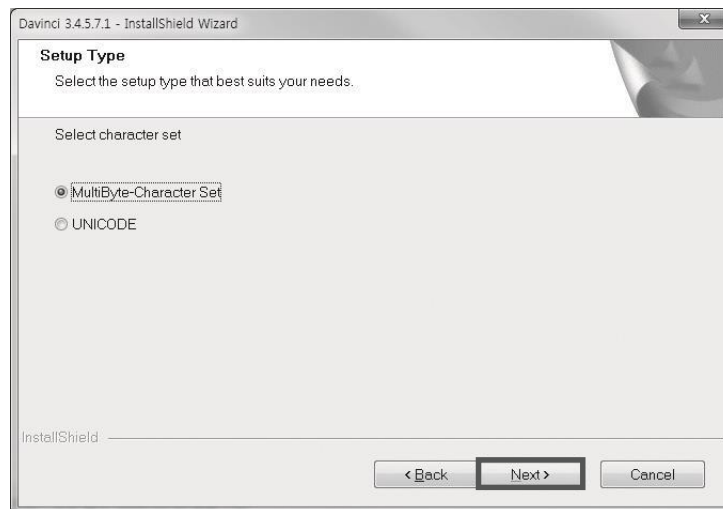

Choose UNICODE if console SW is supporting UNICODE
If Character set is not installed correctly, images will not be properly acquired.

⑥ Click “Install”

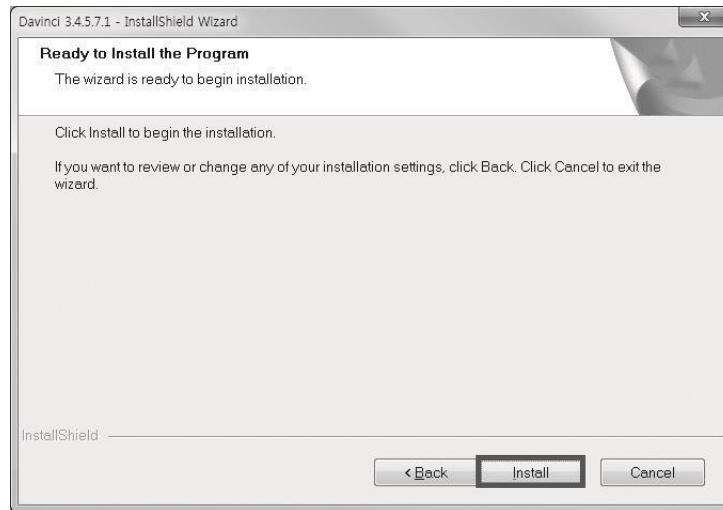

⑦ Click “Finish”

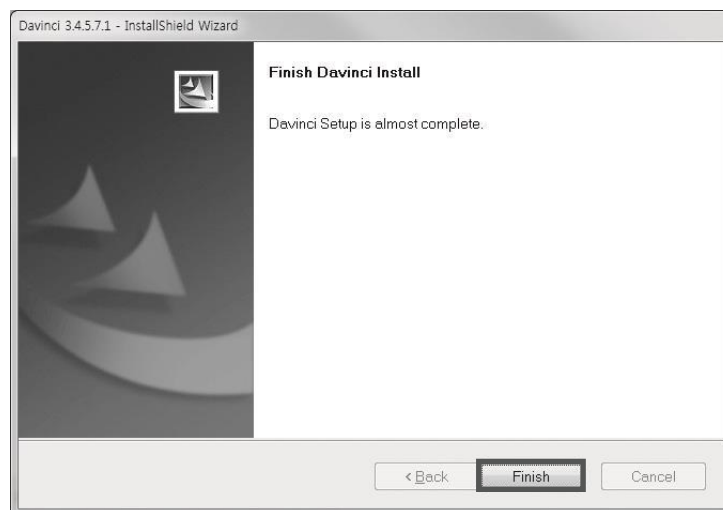

2 Mode Selection

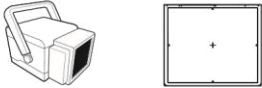
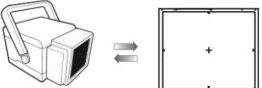
Mode	Description
<p>⟨Auto Trigger⟩</p> 	<p>Automatically detects X-ray radiation without integration of the generator and detector</p>
<p>⟨Manual Trigger⟩</p> 	<p>Detects X-ray radiation by sending and receiving sync signals through the integration between generator and detector</p>

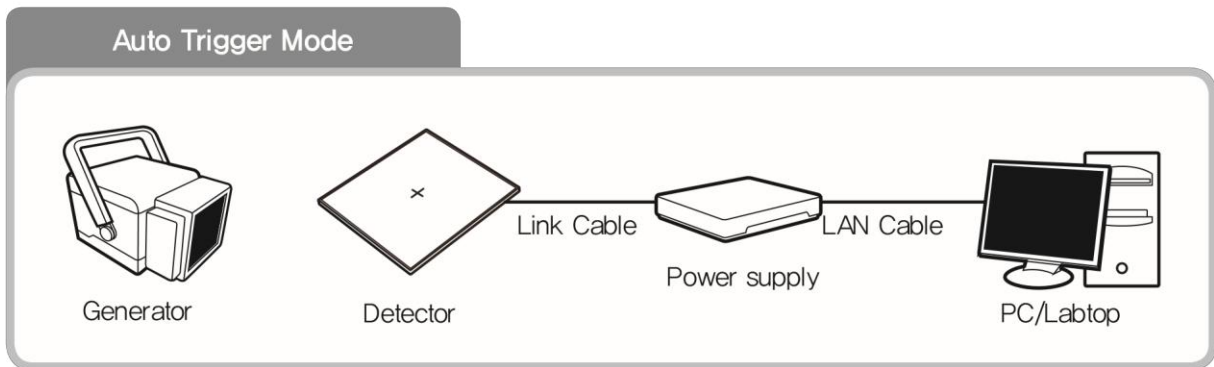

➔ Follow instructions from **3 Product Set up 1, Auto Trigger Mode**

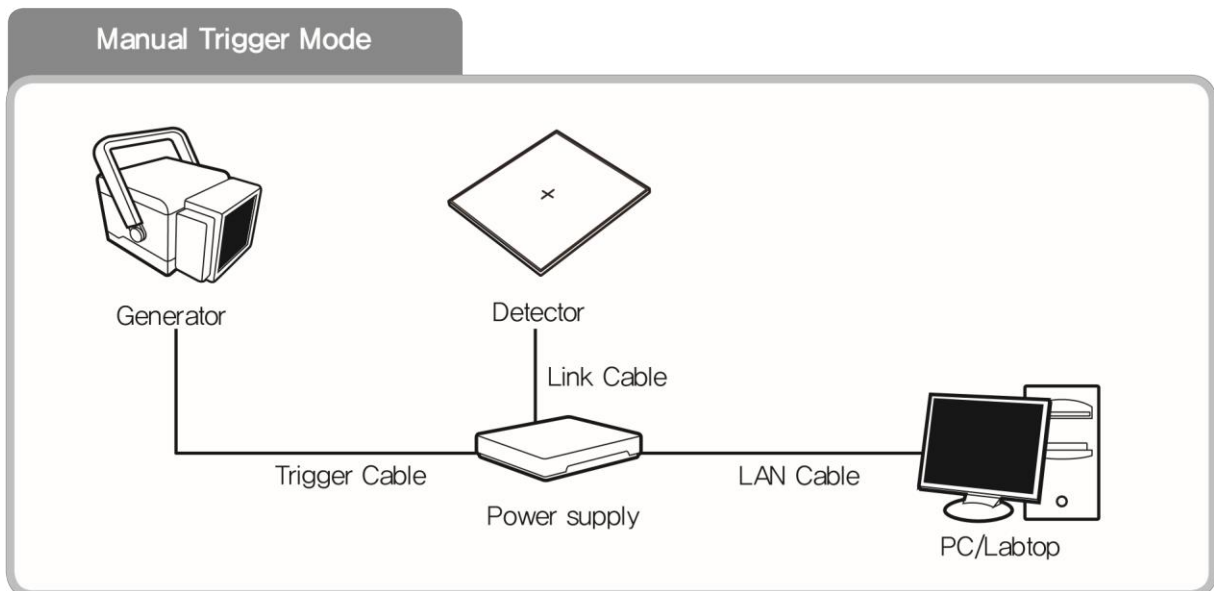

➔ Follow instructions from **3 Product Set up 2, Manual Trigger Mode**

3 Product Set Up

1.Auto Trigger Mode

① Product Set up

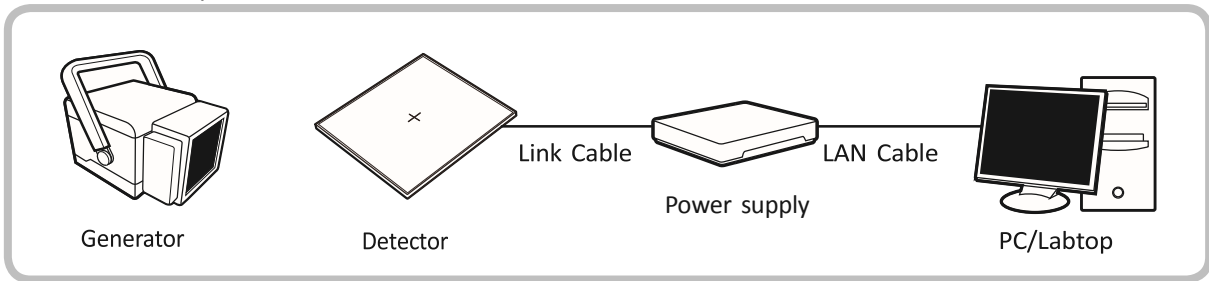

② Connect the cable

>> Connect the Power supply and PC with the LAN cable

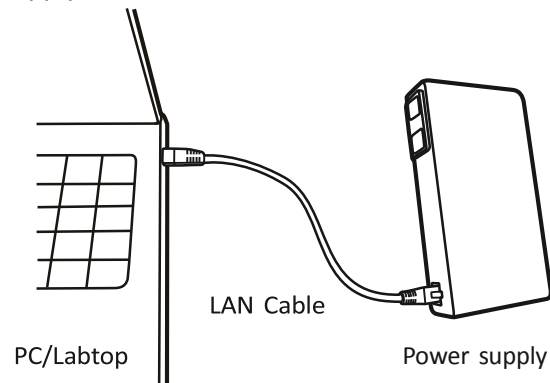

>> Connect the Power supply and Detector with the Link cable

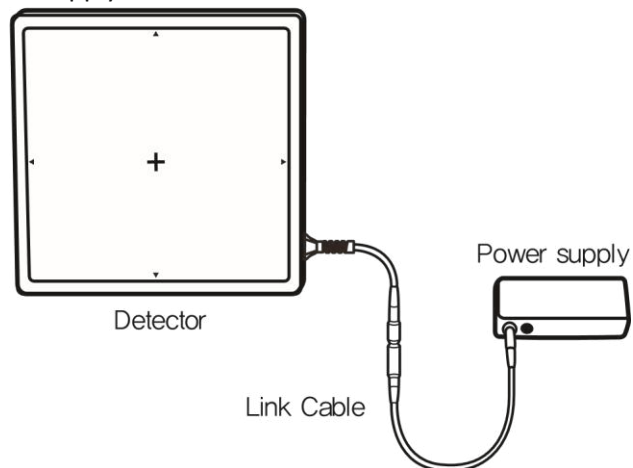

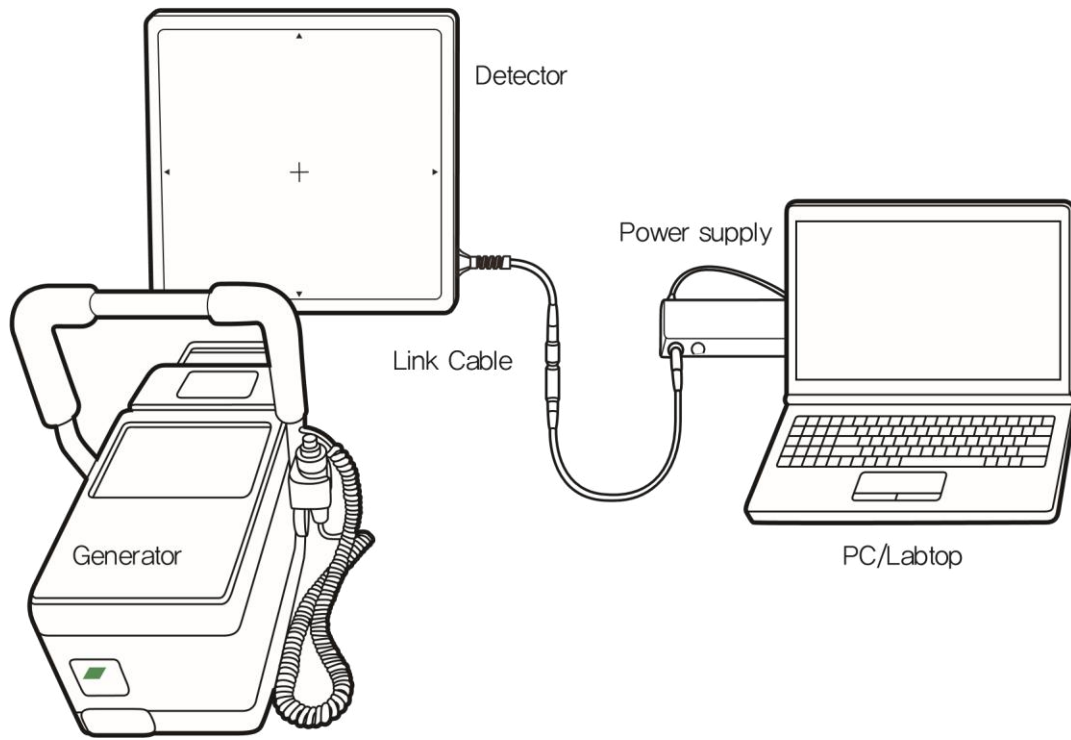

③ PC Set up

>> Set up the Network as below

- Desktop > Network Icon > Right click > Properties > Change Adaptor Settings
- Control Panel > Network and Sharing Center > Change Adaptor Settings

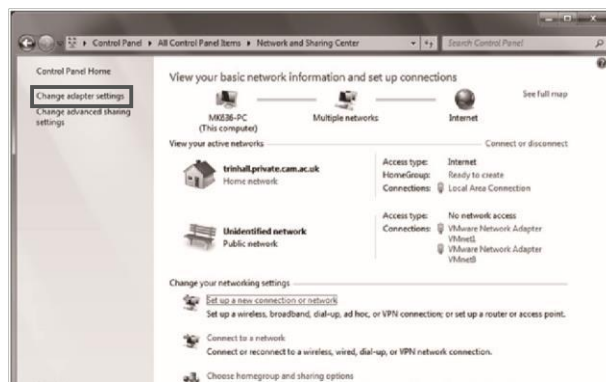
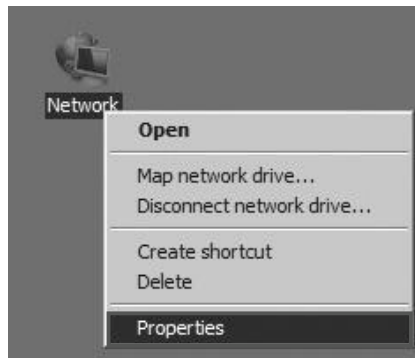

>> Right Click "Local Area Connection" and click Properties

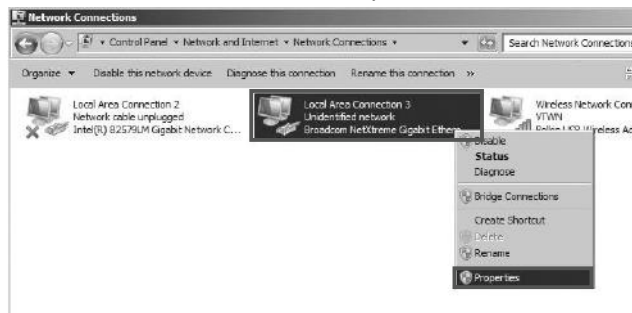

>> Double click “Internet Protocol Version 4 (TCP/IPv4)”

>> Select “Use the following IP address.” Type 192.168.1.20 in the IP address box and 255.255.255.0 in the Subnet mask box and click "OK"

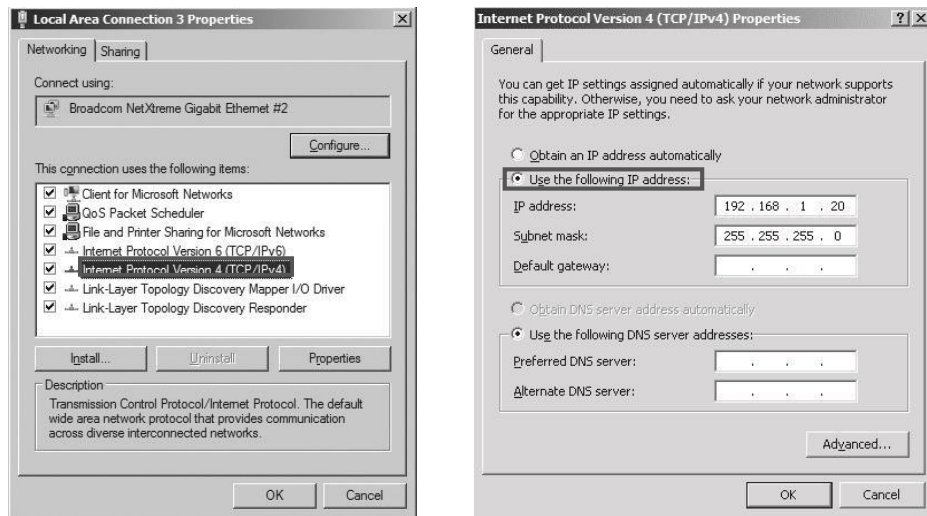

④ Set up SW

>> Connect Detector and turn on the power

>> Open “_vadav.lnk” from “C:\davinci”

Once the program is opened and the detector is connected, the Detector Status will display information of the detector as below.

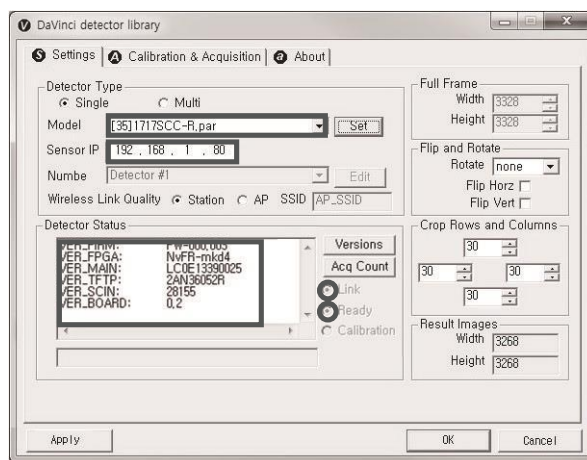

For the 1717SGG [35]1717SCC-R.par gets selected and for the 1717SGC, [36]1717SGC-R.par gets selected.



Default IP address is 192.168.1.80. If the IP address needs to be changed, please refer to Part.2 Service Manual Ch.2.1 Detector IP Address Set Up

If the detector does not communicate with the PC, please check the connection of the cable, PC set up and power of the detector.

>> After checking connectivity, click the "Calibration & Acquisition" tab and click "Edit".

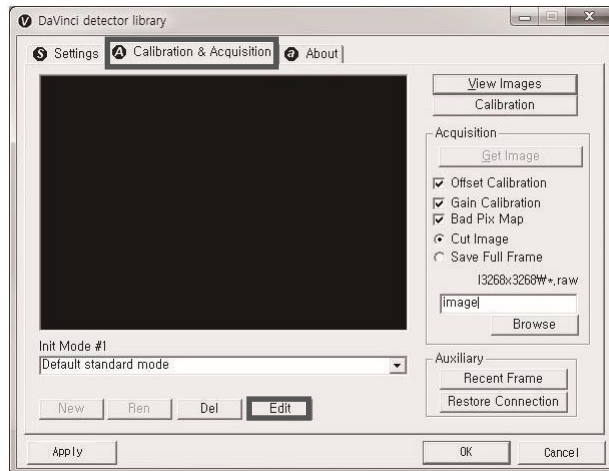

>> Another window will now be opened as shown below. Select "Auto Trigger" from "Trigger Mode". If the "Window time" needs to be changed, type the value at "Window Time" from "Setting".

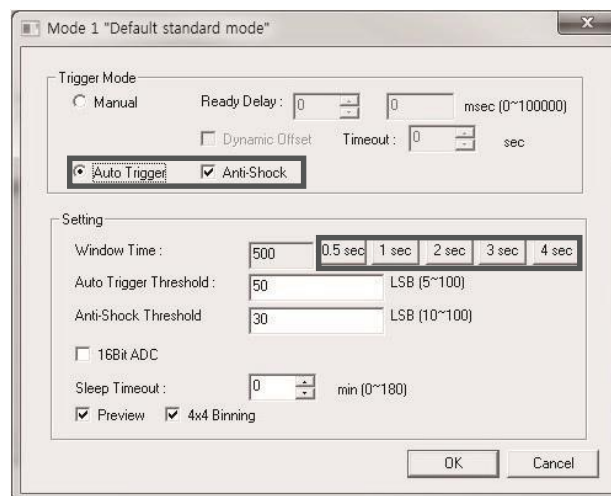

In Auto trigger mode, be sure to set the "Window time" longer than an exposure time. If the "Window time" is shorter than the exposure time, images will not be properly acquired.

2. Manual Trigger Mode

① Product Set Up

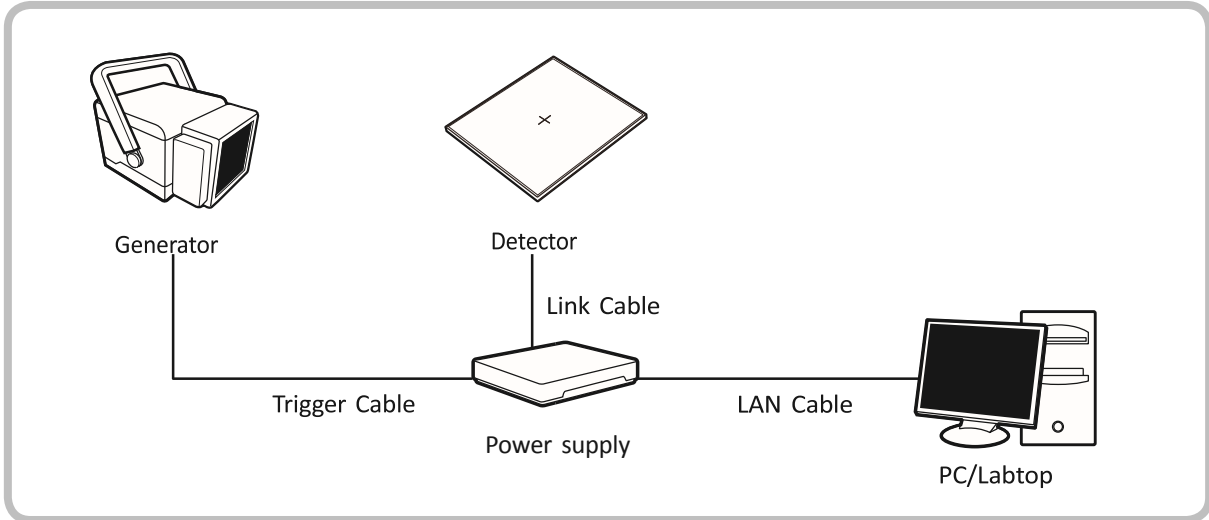

② Connect the cable

>> Connect the Power supply and PC with the LAN cable

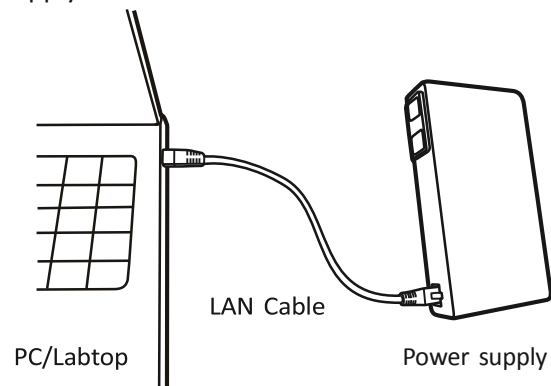

>> Connect the Power supply and Detector with the Link cable

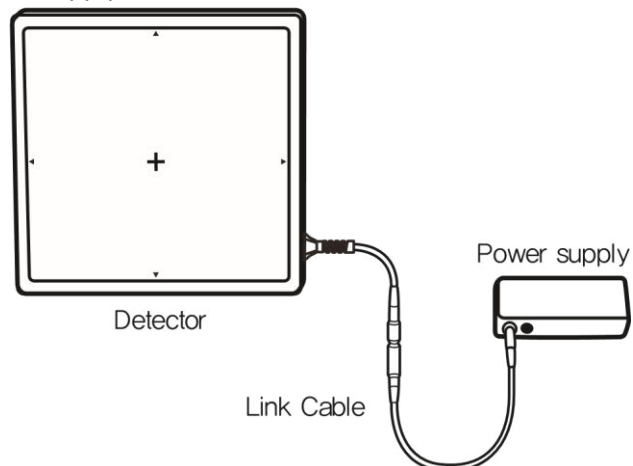

>> Connect the Power supply and generator with the Trigger cable.

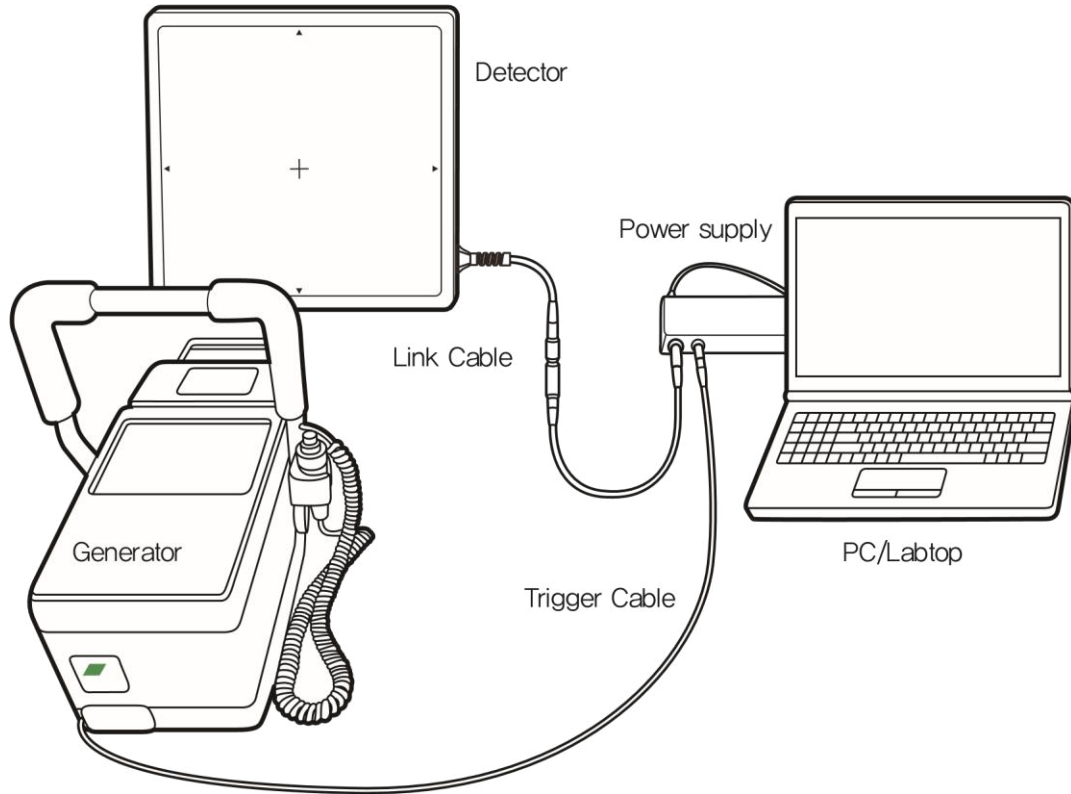

Instruction of Trigger cable Integration

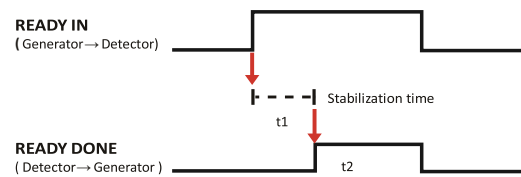
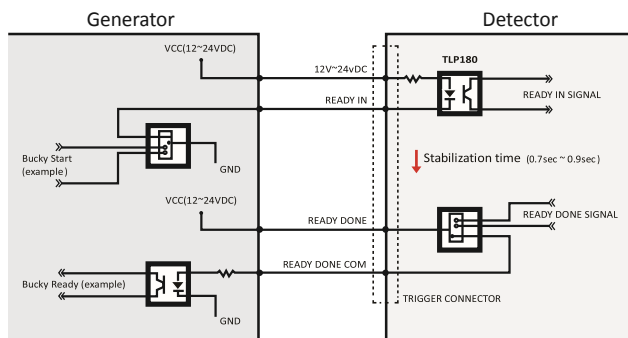

<Assembly Diagram>

<Timing Chart>

③ PC Set up

>> Set up the Network as below

- Desktop > Network Icon > Right click > Properties > Change Adaptor Settings
- Control Panel > Network and Sharing Center > Change Adaptor Settings

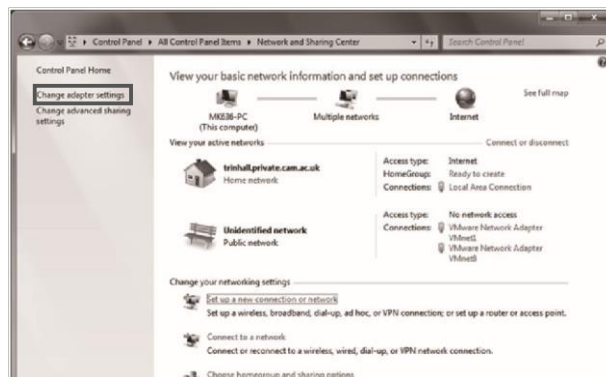
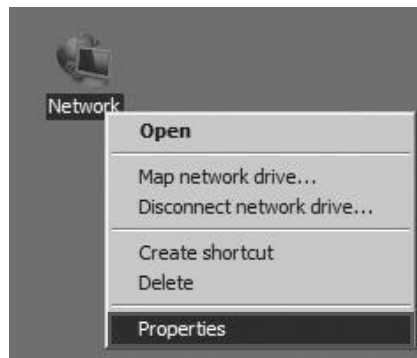

>> Right click "Local Area Connection" and click Properties

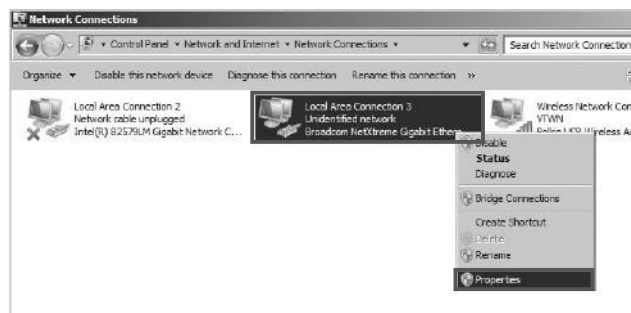

>> Double click “Internet Protocol Version 4 (TCP/IPv4)”

>> Select “Use the following IP address.” Type 192.168.1.20 in the IP address box and 255.255.255.0 in the Subnet mask box and click "OK"

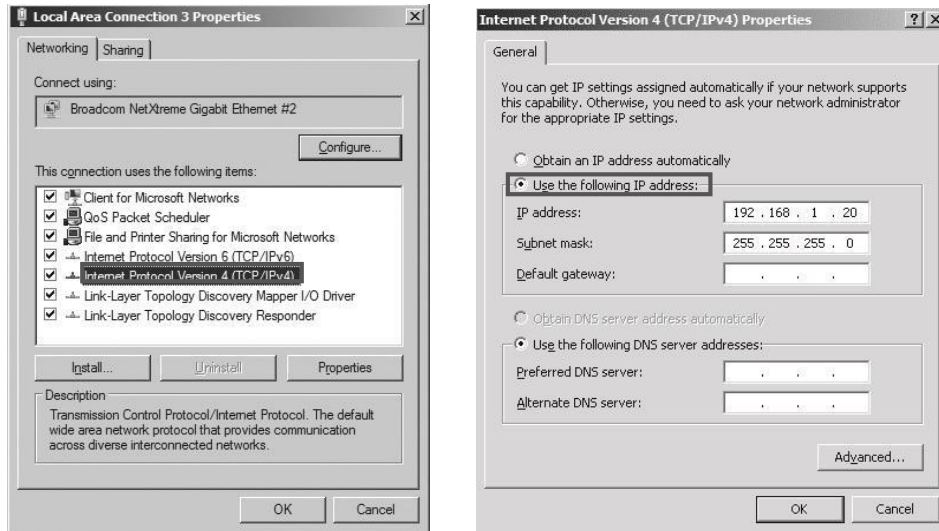

④ Set up SW

>> Connect Detector and turn on the power

>> Open “_vadav.lnk” from “C:\davinci”

Once the program is opened and the detector is connected, the Detector Status will display information of the detector as below.

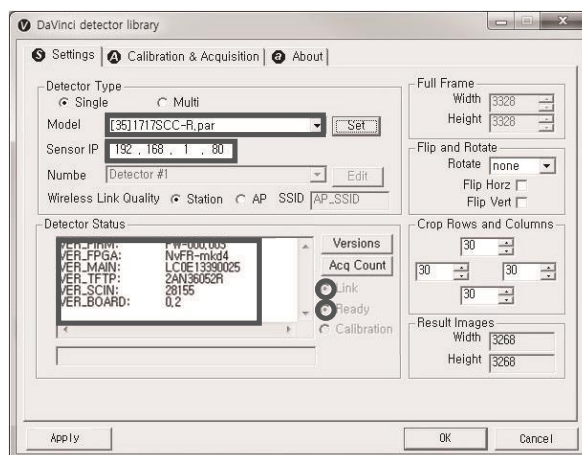

For the 1717SGC, [35]1717SGC-R.par gets selected and for the 1717SGC, [36]1717SGC-R.par gets selected.



Default IP address is 192.168.1.80. If the IP address needs to be changed, please refer to Part.2 Service Manual Ch.2.1 Detector IP Address Set Up

If the detector does not communicate with the PC, please check the connection of the cable, PC set up and power of the detector.

>> After checking connectivity, click the "Calibration & Acquisition" tab and click "Edit".

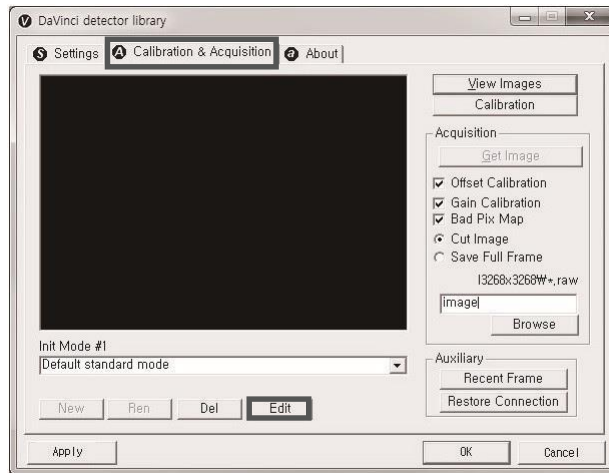

>> Another window will be opened as below once the "Edit" button is pressed. Select "Manual" from "Trigger Mode". If "Window time" needs to be changed, type the value at "Window Time" from "Setting".

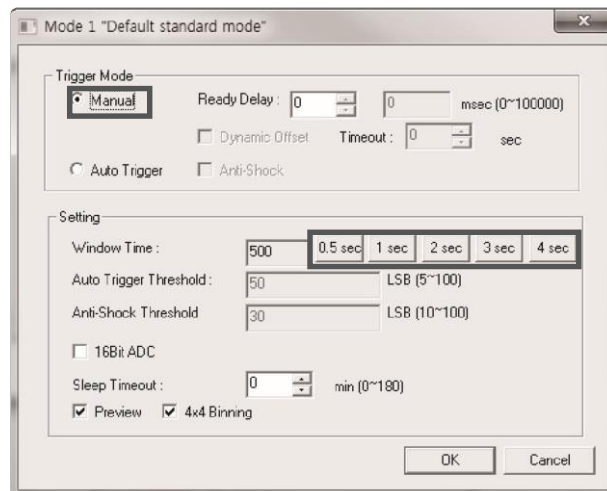

2 Calibration

In order to properly acquire images, calibration must be performed. Without calibration, optimum images cannot be acquired.



#SG HealthCare recommends to warm up the detector for 5 minutes after turning on the power.

Performing a calibration every 6 months is recommended to obtain high quality images.

1 Auto Calibration Mode

- 1 Connect the detector and turn the power on
- 2 Open “_vadav.lnk” from “C:\davinci”
- 3 Once the detector is connected, information of the detector is displayed in Detector Status and Link & Ready are checked as below.

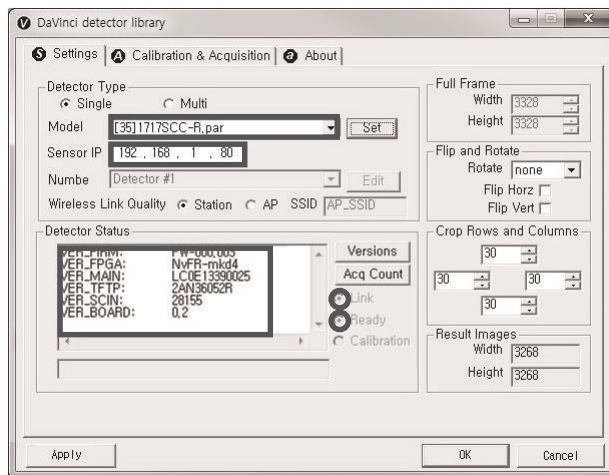

If "Detector Status" does not show anything, please refer to Part.1 User & Installation Manual Ch.3.1 Installation to connect the detector properly.

④ After checking connection, click “Calibration & Acquisition” tab.

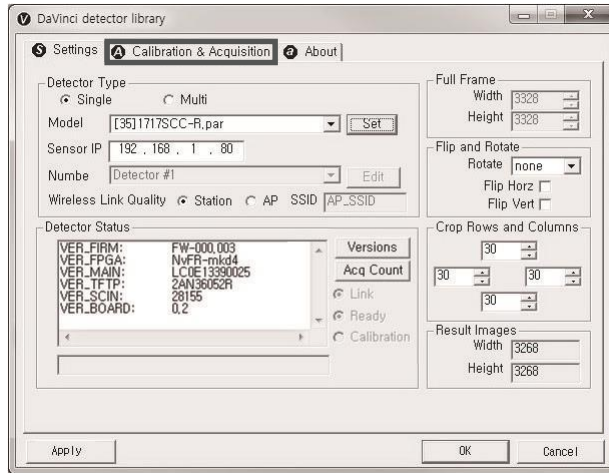

⑤ Click “Calibration”

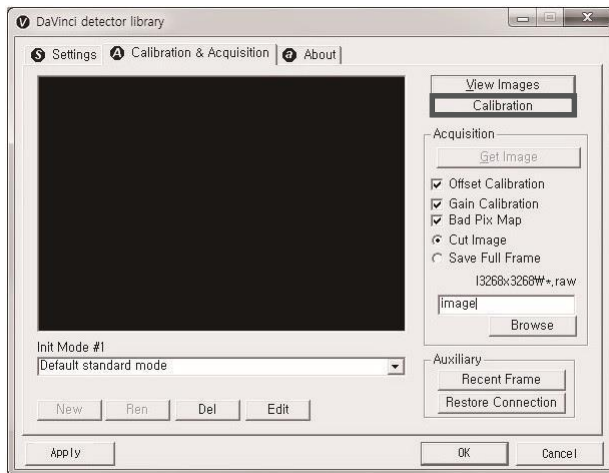

- ⑥ Once "Start" is pressed, the program automatically gets a Dark frame and the acquired Dark frame is stored in "C:\davinci\cal". A Calibration Point file will be created automatically.

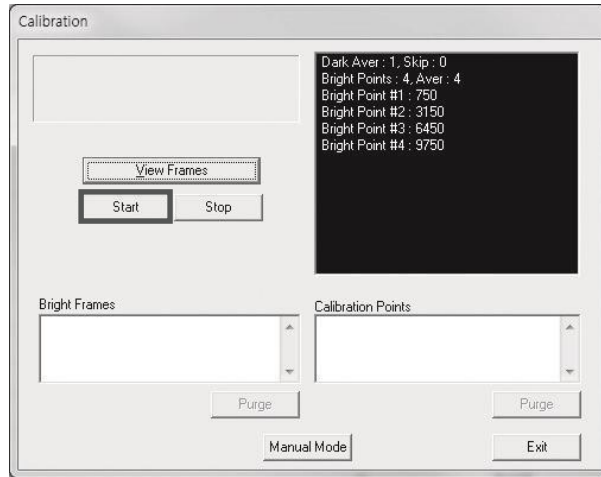

- ⑦ After acquiring the Dark frame, shoot an X-ray when the "Acquiring bright frame" window pops up.

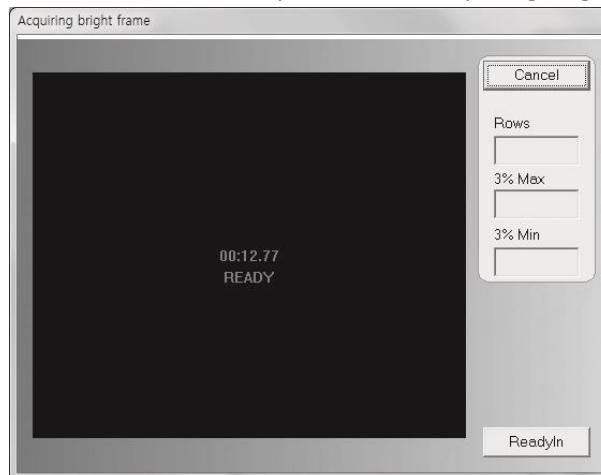

- ⑧ “Acquiring bright frame” is closed after radiation is detected, and the program will show if the detected radiation is within acceptable range.

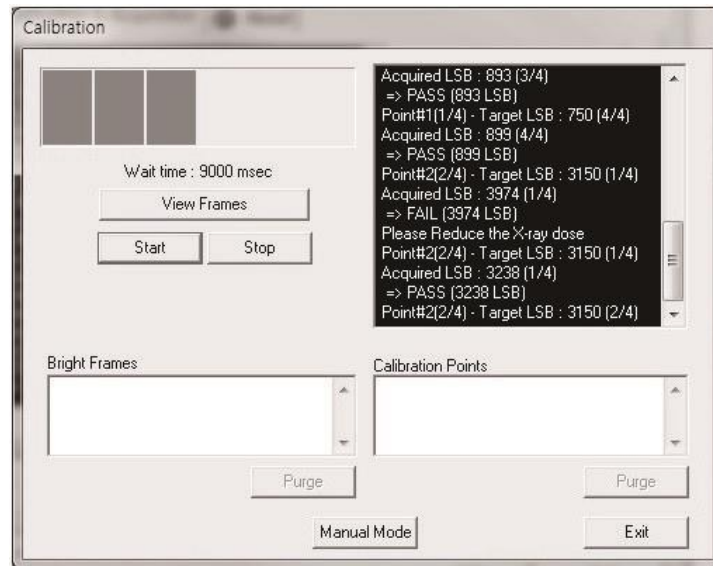

When PASS is displayed	When FAIL is displayed
Shoot X-ray with same technique when “Acquiring bright frame” is popped up.	Adjust technique to get acceptable value and shoot again.

- ⑨ For each Calibration point, four images must successfully be acquired. After successfully doing so for every point, the Calibration process is complete.

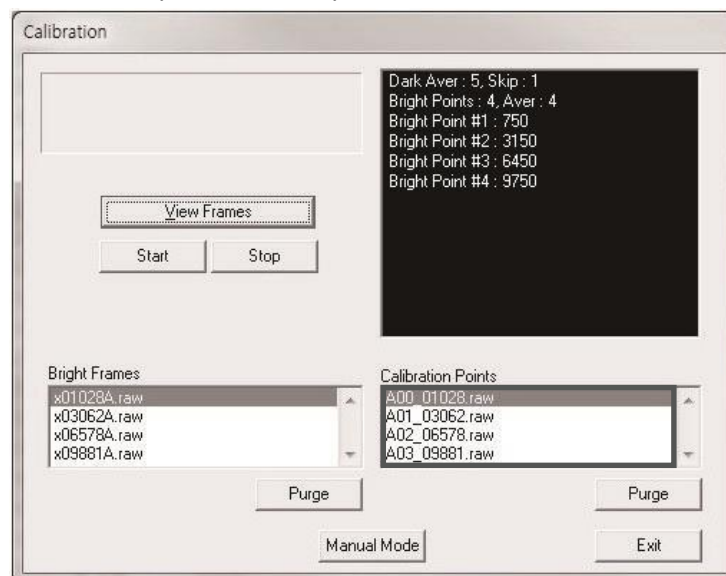

⑩ Click "OK" to move to the next step.

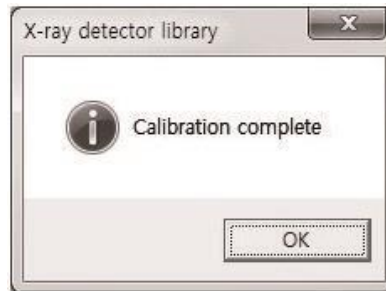

2 Manual Bad Pixel Map Set Up

① Click "Calibration"

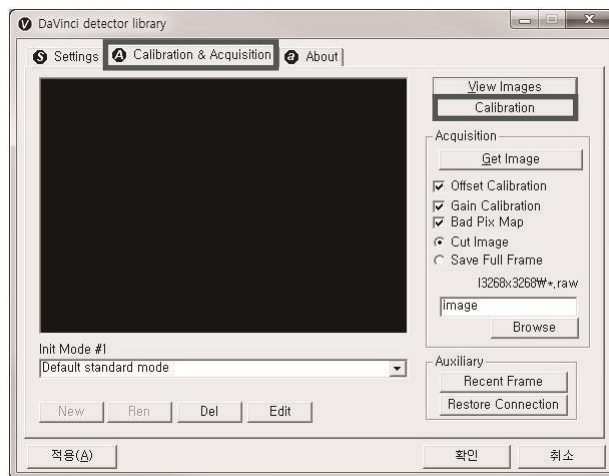

② Click "View Frames"

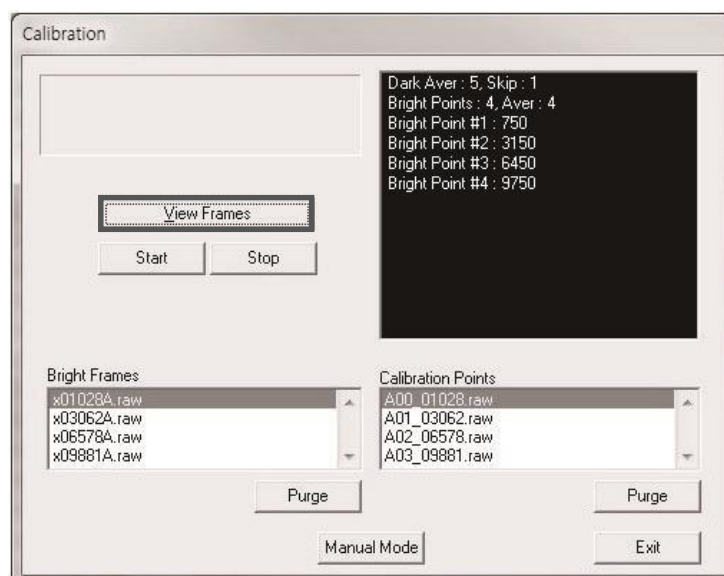

③ Set Manual bad pixel map (BPMM) as below

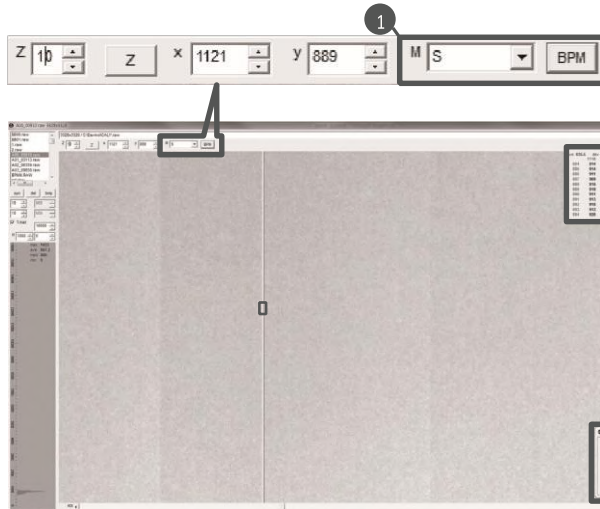

Figure 1. View Image

ave	835.5	dev	354.5	min	21	max	1122	val	1304
884	914	921	920	1221	21	1123	904	911	
885	914	916	910	1266	21	907	903		
886	911	913	913	1219	21	921	910		
887	909	913	922	1305	21	909	917		
888	915	914	914	1274	21	910	918		
889	919	903	899	1304	21	901	915		
890	911	907	918	1245	21	912	916		
891	913	918	915	1283	21	901	908		
892	915	917	920	1303	21	908	908		
893	913	905	918	1262	21	907	899		
894	920	918	915	1252	21	911	906		

Figure 2. Pixel Point

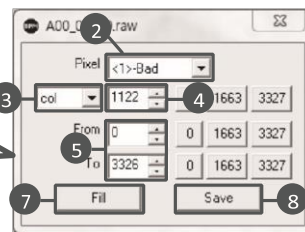

Figure 3. BPMM Control Tab

- ① At Figure 1, choose S from the list of M ① and click "BPM". Check if BPMM window is popped up as Figure 3.
- ② Choose "Bad" from Pixel list (Figure 3 - ②)
- ③ Choose either "row" or "col" from Figure 3 - ③
- ④ Put the coordinate of pixel to set bad pixel at Figure 3 - ④
- ⑤ If bad pixel is a line, put the range as below at Figure 3 - ⑤

	From	To
Row	0	3327
Col	0	3327

If bad pixel is not a line but some pixels, put the rest coordinate at Figure 3 - ⑤.

- ⑥ After completing step ⑤, check if bad pixel has been changed to green as Figure 2 - ⑥
- ⑦ Click "Fill" at Figure 3 - ⑦
- ⑧ Click "Save" at Figure 3 - ⑧

④ Once setting BPMM is done, "BPMM.raw" file will be saved at C:\Davinci\CAL

Ch.4 Usage

1 Set Up

1 Product Connectivity

- 1 Connect the detector and turn on the power
- 2 Open “_vadav.lnk” from “C:\davinci”
- 3 Once the detector is connected, detector information is displayed in Detector Status and Link & Ready are checked as below.

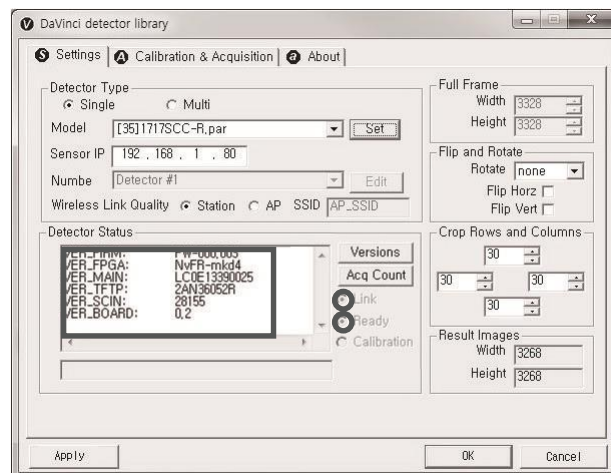

If "Detector Status" does not show anything, please refer to Part.1 User & Installation Manual Ch.3.1 Installation to connect the detector properly.

2 Image Set Up

- ① In order to rotate or flip an image, use the option of "Flip and Rotate" as shown below.
- ② In order to change the size of an image, use "Crop Rows and Columns" as below.
- ③ Click "Apply" to save.

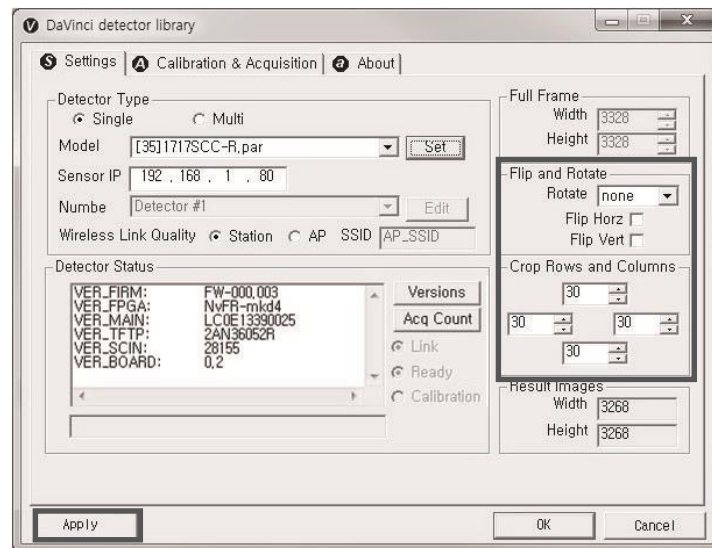

3 Multi Detector Set Up

Refer to Part.2 Service Manual Ch.3 Multi Detector Set Up for Multi-Detector Setting

2 Image Acquisition

1 Product Connection

- ① Connect the detector and turn on the power
- ② Open “_vadav.lnk” from “C:\davinci”
- ③ Once the detector is connected, information of the detector is displayed in Detector Status and Link & Ready & Calibration are checked as below.

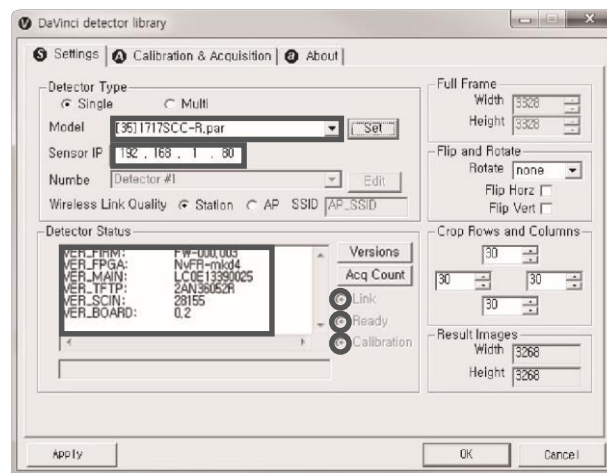

If "Detector Status" does not show anything, please refer to Part.1 User & Installation Manual Ch.3.1 Installation to connect the detector properly.



If Calibration is not checked along with black dots checking off "Link" and "Ready" as above, please refer to Part.1 User & Installation Manual Ch.3.2 Calibration and perform calibration again.

2 Image Acquisition

- 1 Click the "Calibration & Acquisition" tab and type the name of the image inside the marked box below. After naming the image, click "Get Image".

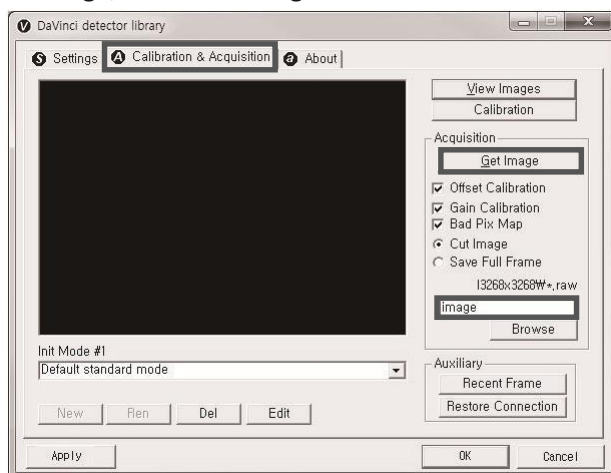

- 2 Shoot an X-ray once the "Acquiring bright frame" window pops up.

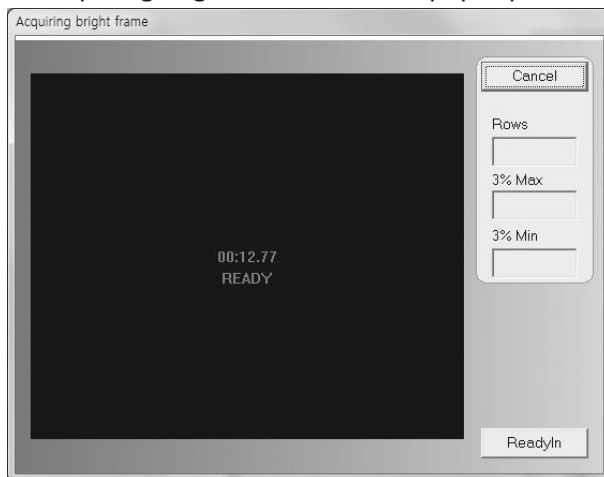

- 3 An acquired image will be stored in "C:\davinci\I3268x3268" and the name of the file will be "(typed name from Step 1).raw".
- 4 The format of the stored file is 16 bit little-endian order.

3 View Images

① Click “View Images”

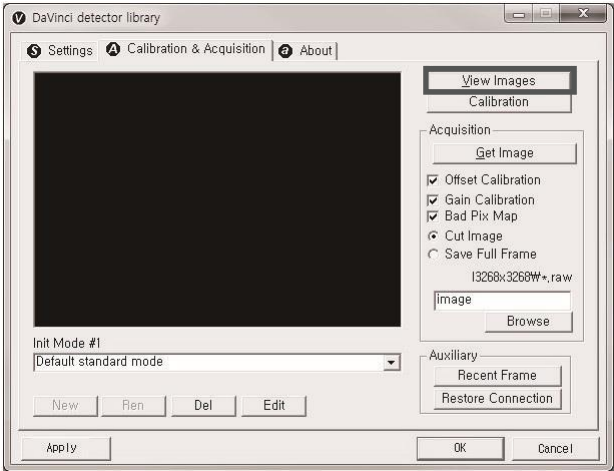

② Another window will be popped up as below.

Histogram Set Up

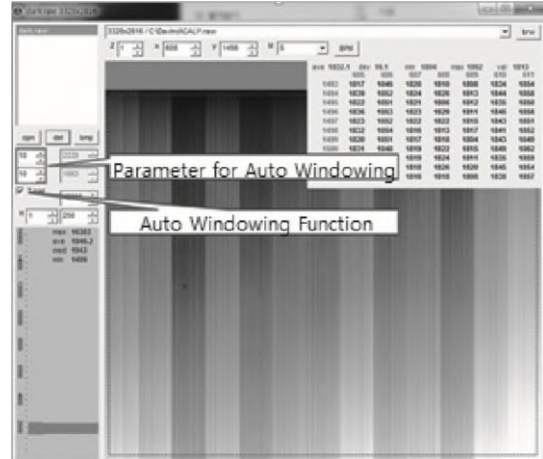
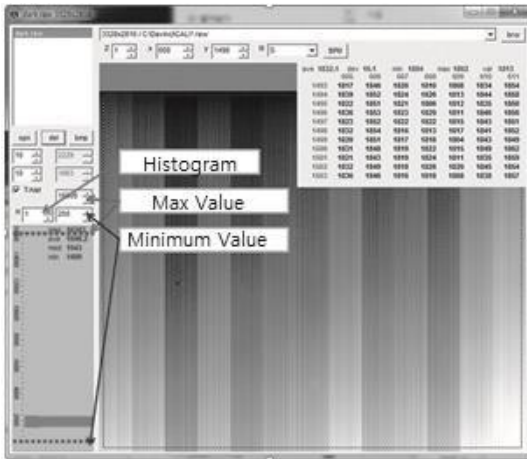

Pixel value at certain level

>> Choose "S" from the marked box

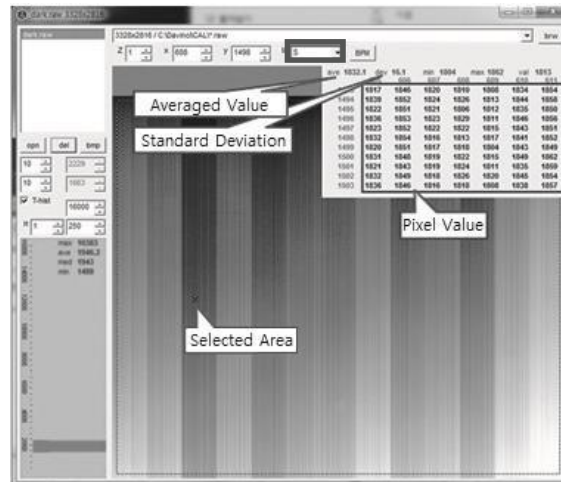

Profile for horizontal line

>> Choose "R" from the marked Box

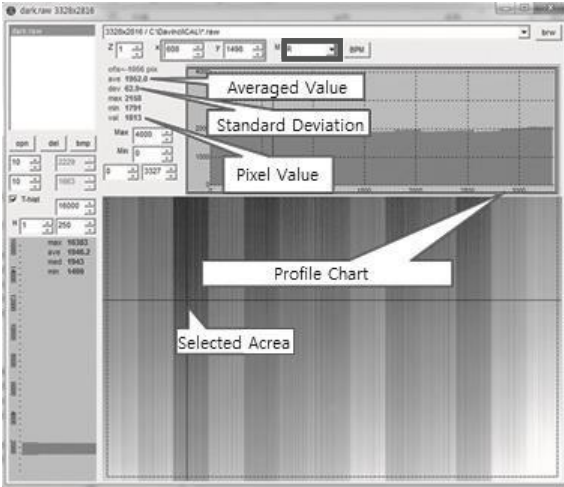

Profile for vertical line

>> Choose "C" from the the marked box

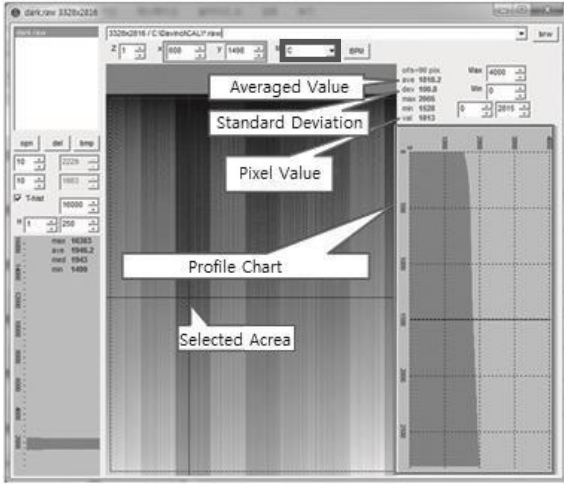

4 Additional Function

1 Recent Frame

>> The last acquired image can be opened by clicking "Recent Frame" under the "Calibration & Acquisition" tab.

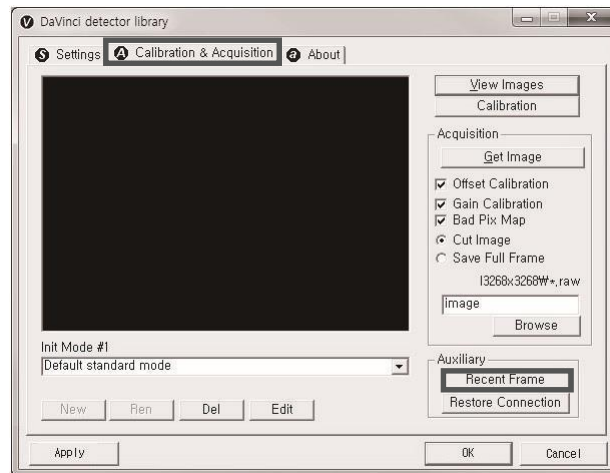

2 Restore Connection

>> When the connection between the detector and PC is lost, the connection can be made again by clicking "Restore Connection" under the "Calibration & Acquisition" tab.

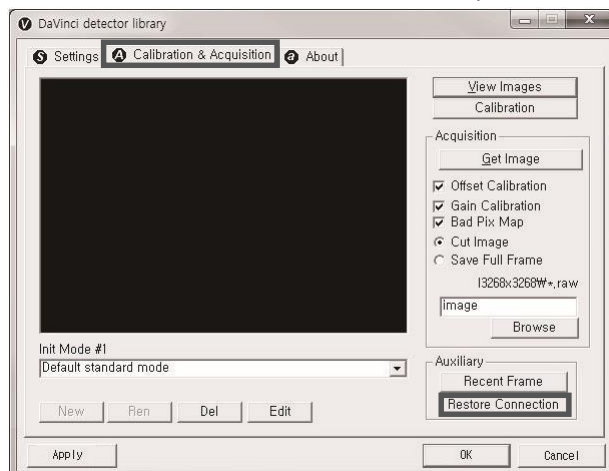

3 Preview

>> Click the "Calibration & Acquisition" tab and click "Edit".

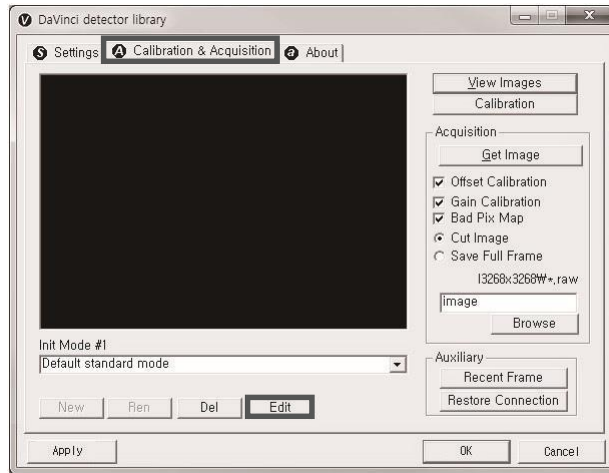

>> After checking the Preview and 4x4 Binning, a 4x4 binned image appears which allows for a quicker image preview.

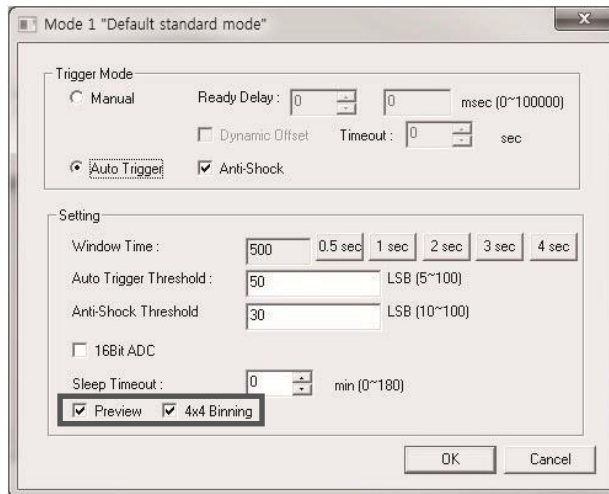

By unchecking 4x4 Binning, a normal image preview appears.

By unchecking Preview, a full frame image appears.

Ch.5 Maintenance

1 Cleaning

- 1 Clean the detector with IPA (Isopropyl-alcohol) when it is contaminated.
- 2 Before cleaning the detector, turn off the power.
- 3 Wear waterproof gloves to protect your hands from direct contact with IPA or any other liquid.
- 4 Do not pour or spray IPA directly on the detector. Use fabric or soft cloth moistened with IPA to clean.
- 5 Avoid getting IPA or any other liquid into the detector.
- 6 After cleaning, wait until the IPA is dried completely.

2 Inspection

- 1 In order to ensure that the detector is used safely and normally, please be sure to inspect the product regularly before use. If any problem occurs, please contact SG HealthCare Customer Service team.
- 2 Please perform inspections based on the check list below.

Inspection List	User	Vendor	Cycle
Check if cables are not damaged	<input type="checkbox"/>		Daily
Check if plugs and connectors are not loose or damaged	<input type="checkbox"/>		Daily
Check if cover or part is not damaged	<input type="checkbox"/>		Daily
Check the LED indicator	<input type="checkbox"/>		Daily
Re-Calibration		<input type="checkbox"/>	Half Year
Check the performance of the product by doing test shots with Phantom or resolution chart		<input type="checkbox"/>	Yearly

3 Replaceable Parts and Instructions for Replacement

1 Fuse: T3.15 AL 250V

>> Replacing the Fuse

① Press the fuse as below and pull the fuse box

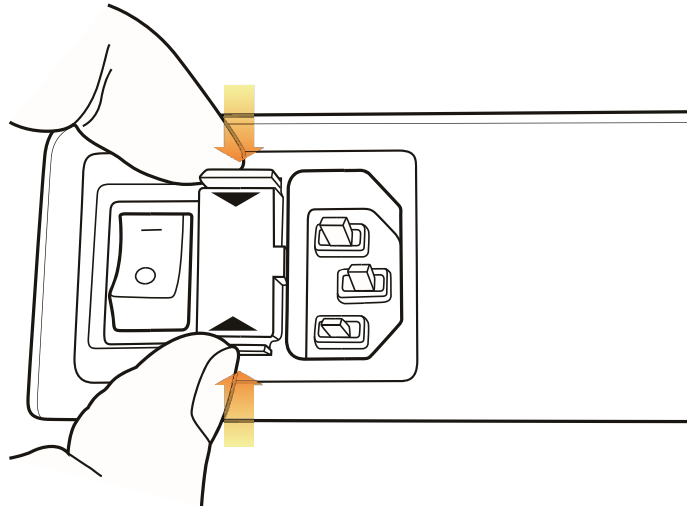

② Pull the fuse and replace with another fuse

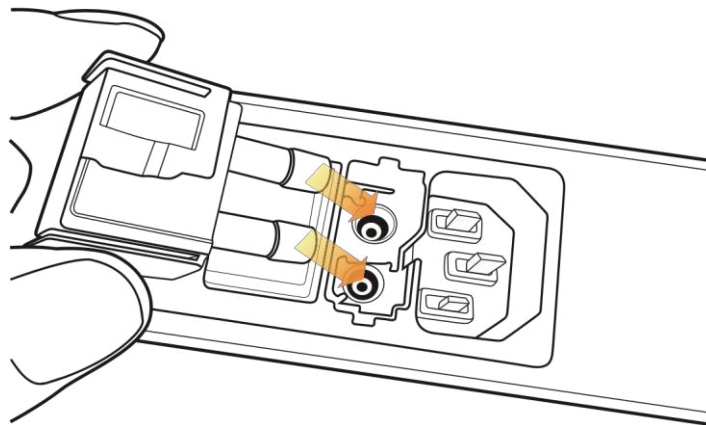

2 Power cord: H05VV-F 0.75SQ * 3C

3 Ethernet Cable: UTP 4PR 24AWG (CAT.6, direct type)

4 Disposal or Recycling

Follow local governing ordinances and recycling plans regarding the disposal or recycling of device components.



Disposal of old Electrical & Electronic Equipment

(Application in the European Union and other European countries with separate collection system.) This symbol indicates that this product shall not be treated as household waste. Instead, it shall be handed over to the applicable collection point for the recycling of electrical and electronic equipment. By ensuring this product is disposed of correctly, you will help prevent potential negative consequences for the environment and human health, which could otherwise be caused by inappropriate waste handling of this product. For more detailed information about recycling this product, please refer to local governing ordinances and recycling plans.

6. Warranty

SGHEALTHCARE hereby warrants 1717SGC/SGG ("Product") against defects in material and workmanship under normal usage and service for a period of 24 months from the date of installation. If Buyer promptly notifies SGHEALTHCARE or Seller regarding any parts that fail to perform as specified under normal usage during the Warranty Period and SGHEALTHCARE determines that such failure resulted from a defect in materials or workmanship during the Warranty Period, then SGHEALTHCARE, at its option, shall repair, rebuild or adjust the affected parts.

SGHEALTHCARE shall have no obligation for any defects to the extent that such defect arises out of (i) normal and fair wear and tear or Product which has been modified without SGHEALTHCARE's approval, (ii) Product which has not been installed in strict conformity to the SGHEALTHCARE's directions or which have been subjected to electrical or other abuse, or damaged by improper handling, storage or use by Buyer or a third party, (iii) use of Product in combination with devices or products not purchased from SGHEALTHCARE; (iv) use or application of Product in a field or in an environment for which such Product was not designed or contemplated; (v) use of any parts or material not provided by SGHEALTHCARE for warranty service; or (vi) the third party's maintenance not certified by SGHEALTHCARE; or (vii) force majeure such as natural disaster.

The remedies contained in this warranty are Buyer's exclusive remedies. SGHEALTHCARE shall not, in any event or under any circumstances, be responsible for damages or other sums in excess of the total purchase price actually paid by Buyer to Seller i.e., SGHEALTHCARE or SGHEALTHCARE's authorized agent. Without limiting the generality of the foregoing under no circumstance shall SGHEALTHCARE be responsible or liable in any regard with respect to damages from loss of use, loss of time, loss of data, inconvenience, commercial loss, lost profits or savings, or other incidental, special or consequential damages claimed by Buyer to arise out of the use or inability to use the Product, even if Buyer has been advised of the possibility of such damages.

In the event that the product is returned to SGHEALTHCARE after the warranty has expired, SGHEALTHCARE reserves the right to invoice a reasonable fee for the repair services provided to Buyer.

SGHEALTHCARE shall make the sole final determination about whether the fail to perform occurred in normal usage (under warranty) or not (excluded from warranty). If the authorized agent or the Buyer doesn't accept the result of SGHEALTHCARE's investigation, the burden of proof is on them.

Warranty Procedure

If Buyer needs to make a claim based on this Warranty, Buyer should advise Seller in writing immediately at the following address:

SGHEALTHCARE Co., Ltd.

753 ITECO, 150 Jojeong-Daero, Hanam-Si, Gyeonggi-do, Korea 465736

Tel: +82-31-790-0647 Fax: +82-31-790-0604

E-mail: service@sghealthcare.com

www.sghealthcare.com

Part.2 Service Manual

| Table of Contents – Technical Service |

1. Overview.....	70
2. FPD Manager Instruction (IP Set Up / Firmware, FPGA Update)	71
2.1 Detector IP Address Set Up	71
2.2 Firmware, FPGA Update	74
2.3 Set Windows Firewall to use FPD_Manager (For Win 7).....	77
3 Multi Detector Set Up	79
4. Troubleshooting.....	83
4.1 LAN Connection Issue	83
4.2 Lost IP Address.....	84
4.3 Auto Trigger Mode.....	84

Ch.1 Overview

This service manual gives additional instructions for setting up the detector.

Ch.2 FPD Manager Instruction (IP Set Up / Firmware, FPGA Update)

2.1. Detector IP Address Set Up

- ① Turn on the power of detector and connect with PC
- ② After the power of detector is on, open "FPD_Manager.exe"
- ③ Type detector's current IP address at "Detector IP Address" from "Current Setting" as below



Detector's Ethernet Controller is operated with Second IP address, 192.168.124.80.

The screenshot shows the FPD Manager V1.0.0.4 (build 1.4.8.18) application window. The 'Current Setting' section is highlighted with a black box, showing the 'Detector IP Address' field containing '192 . 168 . 1 . 80'. Below this, there are sections for 'IP Change', 'Station Mode Setup', and 'Firmware/FPGA Update'. The 'Station Mode Setup' section is checked, and the 'AP Mode Setup' section is also checked. The 'Firmware/FPGA Update' section has an 'Uploading' progress bar and two 'Select' buttons for 'Firmware' and 'FPGA'. At the bottom, there are 'Start Setting' and 'Exit' buttons.

- ④ Select "IP change" and type the IP address. Click "Start Setting". (Wired Model does not need to fill the "Wireless IP address" box.)

FPD Manager V1.0.0.4 (build 1.4.8.18)

Current Setting
Detector IP Address: 192 . 168 . 1 . 80 Get Current Settings

IP Change
Change to
Wired IP address: 10 . 0 . 0 . 80
Subnet Mask: 255 . 0 . 0 . 0
Wireless IP address: 10 . 0 . 0 . 81

Station Mode Setup AP Mode Setup

Station Mode Setup Setting:
External AP's SSID:
PSK (Pre-Shared Key):

AP Mode Setup Setting:
HostAP's SSID:
PSK (Pre-Shared Key):
Frequency (Ghz):

Firmware/FPGA Update Uploading
Firmware: Select
FPGA: Select

Start Setting

Exit

- ⑤ Click "OK" once the message below pops up.

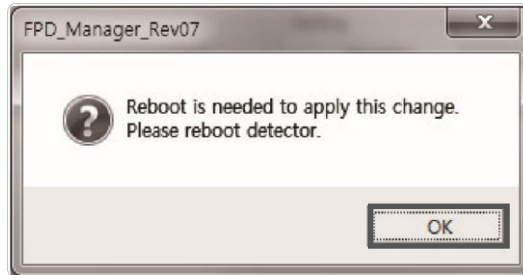

- ⑥ Click "OK" again once the message below pops up.

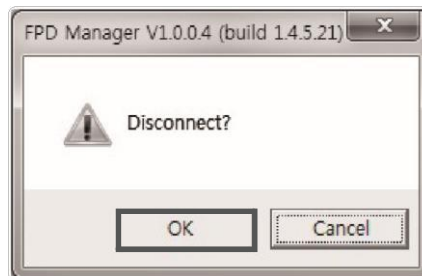

- ⑦ Turn off the power of the detector and after 5 seconds, turn the power back on.

2.2 Firmware, FPGA Update

- ① Turn on the power of the detector and connect it to the PC
- ② After the power of detector is on, open "FPD_Manager.exe"
- ③ Type the detector's current IP address in "Detector IP Address" from "Current Setting" as below



Detector's Ethernet Controller is operated with Second IP address, 192.168.124.80.

The screenshot shows the FPD Manager V1.0.0.4 (build 1.4.8.18) application window. The 'Current Setting' section is highlighted with a black box, showing the 'Detector IP Address' field set to '192 . 168 . 1 . 80'. Below this, there are sections for 'IP Change', 'Station Mode Setup', and 'AP Mode Setup'. The 'AP Mode Setup' section is checked and contains fields for 'HostAP's SSID', 'PSK (Pre-Shared Key)', and 'Frequency (Ghz)'. At the bottom, there are sections for 'Firmware/FPGA Update' with 'Firmware' and 'FPGA' fields, and a 'Start Setting' button.

- ④ Select "Firmware/FPGA Update" and click "Select" to browse the Firmware and FPGA. Once the files are selected, click "Start Setting"



- Firmware File: File extension is either Davinci or tar.
- FPGA file: File extension is bin.

- ⑤ Click "OK" once the message below pops up.

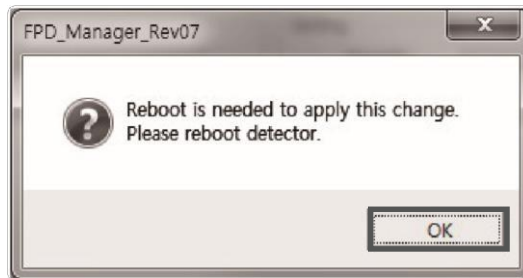

- ⑥ Click "OK" again once the message below pops up.

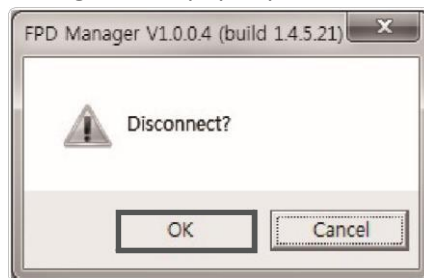

- ⑦ Turn off the power of detector and after 5 seconds, turn the power back on.



Detector IP address might be changed to 192.168.1.80 after updating depend on Firmware.

2.3 Set Windows Firewall to use FPD_Manager (For Win 7)



FPD_Manager would not be performed properly if Windows Firewall blocks FPD_Manager. Please follow the steps below in this case

① 'Control Panel' -> 'Windows Firewall' -> 'Allow an app or feature through Windows Firewall'

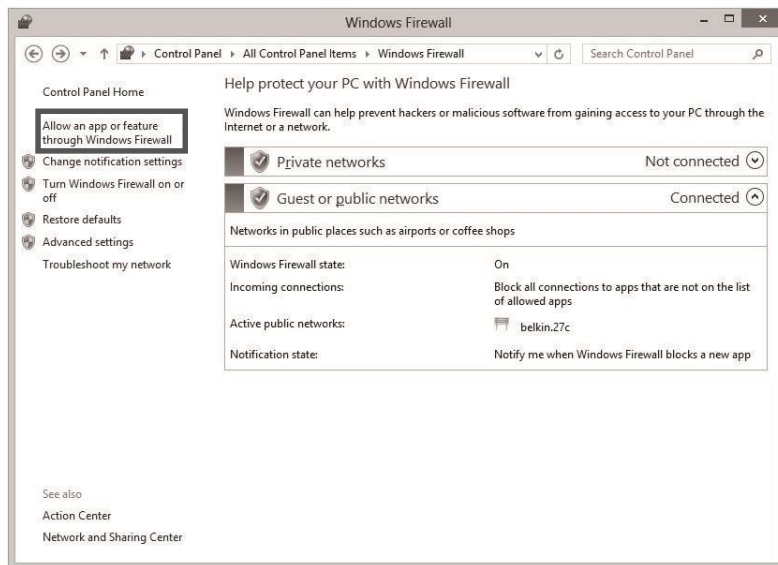

② Check "Name", "Private" and "Public" if FPD_Manager program is already on the list. Click "Allow another app..." when FPD_Manager program is not on the list.

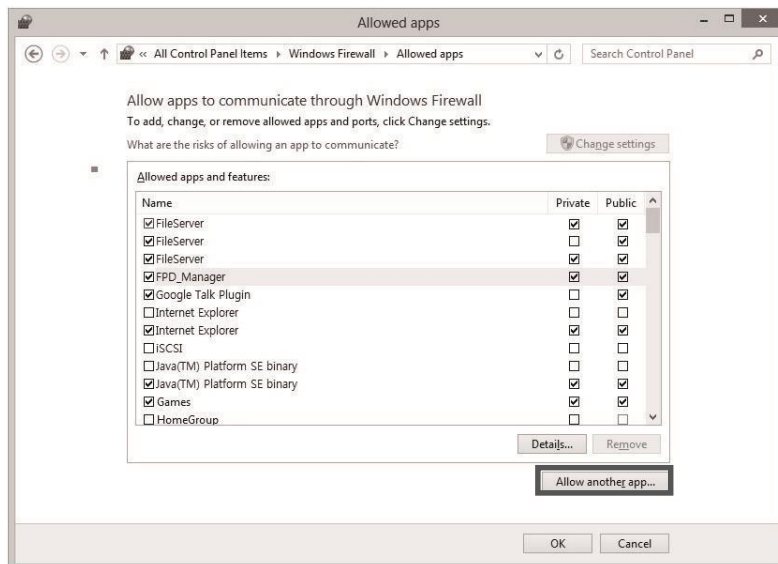

- ③ Select the program and add if it is already on the list. Click "Browse" when the program is no on the list.

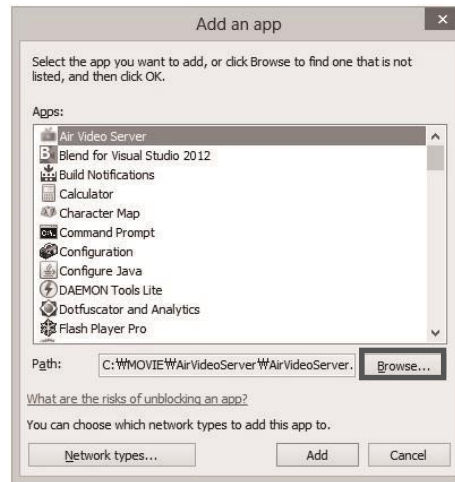

- ④ Browse and open FPD_Manager program and repeat step ②.

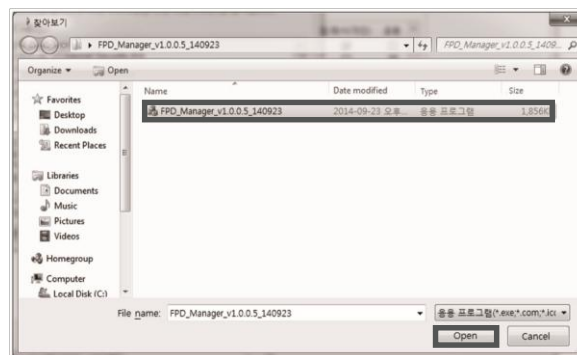

Ch.3 Multi Detector Set up

- ① Open “_vadav.lnk” from “C:\davinci”
- ② Click "Edit" under the "Settings" tab

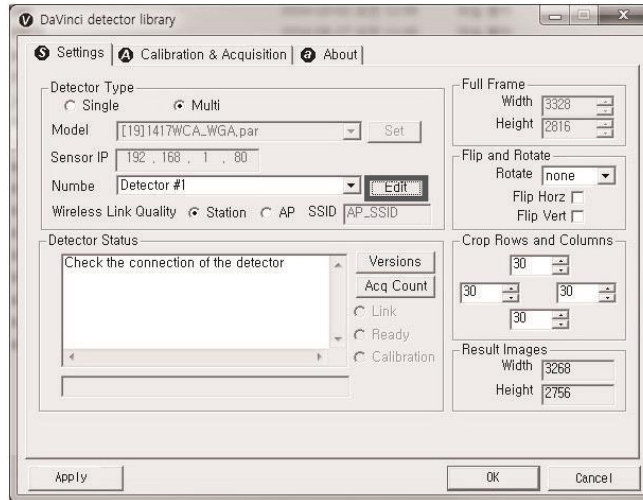

- ③ Select "Detector #1". Choose the product model and type the IP address.

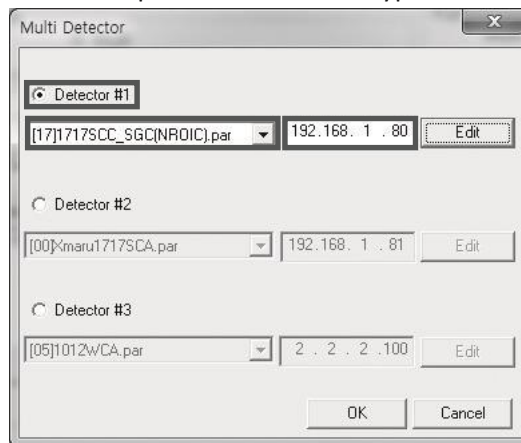

- ④ Click "Edit" from "Detector #1". Set up the "Trigger Mode" and "Setting"

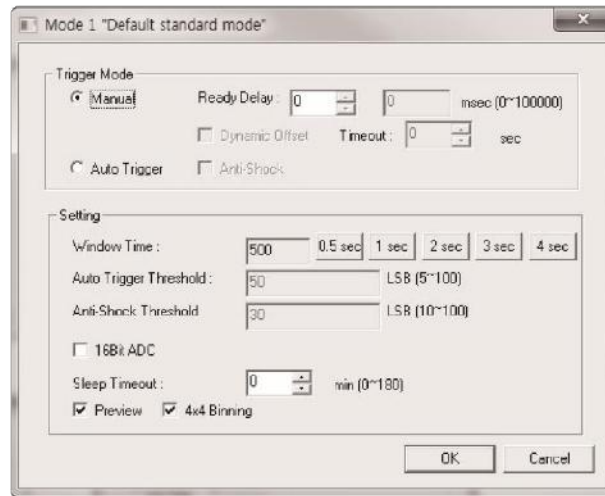

- ⑤ Select "Detector #2". Choose the product model and type the IP address.

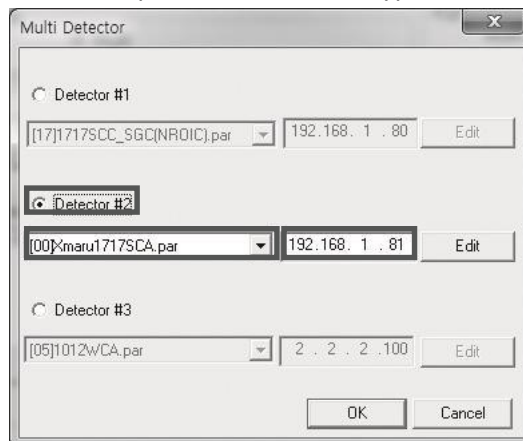

- ⑥ Click "Edit" from "Detector #2". Set up the "Trigger Mode" and "Setting"

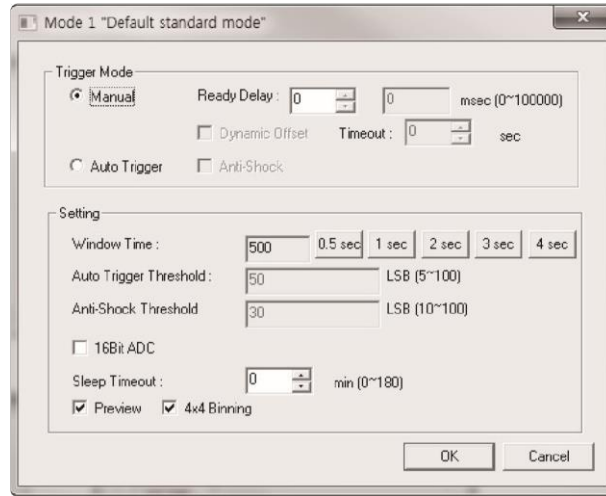

- ⑦ If a third detector is being used, select "Detector #3". Choose the product model and type the IP address.

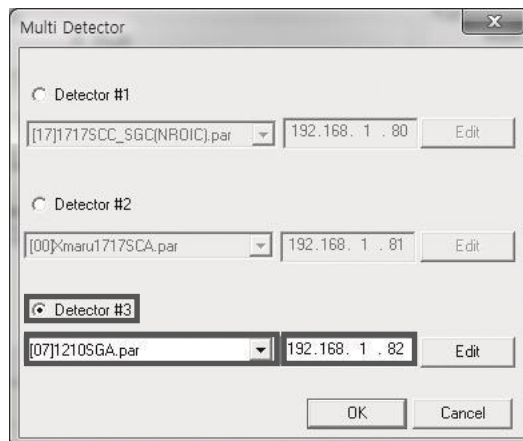

⑧ Click "Edit" from "Detector #3". Set up the "Trigger Mode" and "Setting"

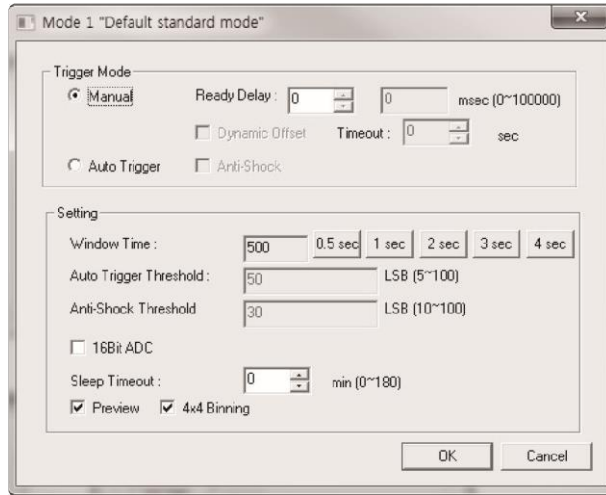

⑨ Choose the detector from the "Number" option and perform the calibration.

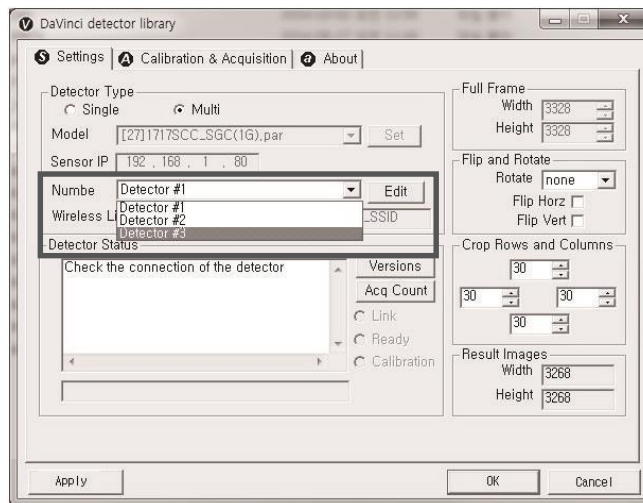

#The calibration folder is named according to the third and fourth numbers of the IP address. (e.g. C:\Davinci\CAL_01_80)

For further instructions on calibration, please refer to Part.1 User & Installation Manual Ch.3.2 Calibration

Ch.4 Troubleshooting

If any problem occurs during the usage of the product, please use this chapter as a troubleshooting guide.

Follow the instructions to resolve the problem. If the problem is not resolved, please contact our SG HealthCare Customer Service team (E-mail : service@sghealthcare.com, TEL : +82-31-790-0647).

4.1 LAN Connection Issue

① Check the cable connectivity

>> Check the link cable and the power cord are connected properly. >>

Check that the power of the detector is on

② Check PC Set up

>> Make sure that the IP address is set to "192.168.1.20" from "Internet Protocol Version 4 (TCP/IPv4)".

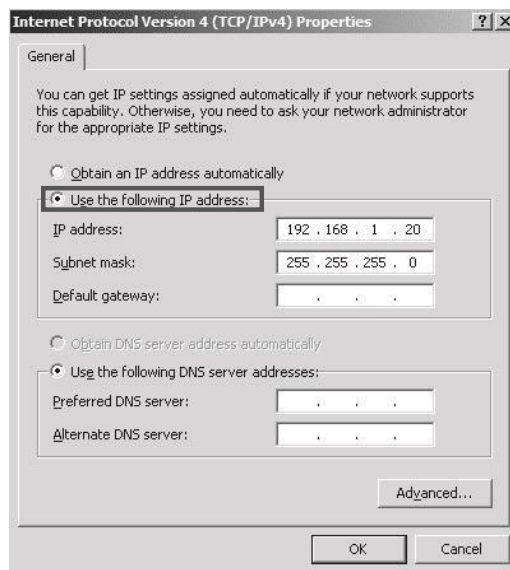

4.2 Lost IP Address

Use a second IP address (192.168.124.80) and change the IP address.

4.3 Auto Trigger Mode

Follow these instructions when the panel auto triggers on its own and/or unintentionally acquires blank images

- ① Open “_vadav.lnk” from “C:\davinci”
- ② Click the "Calibration & Acquisition" tab

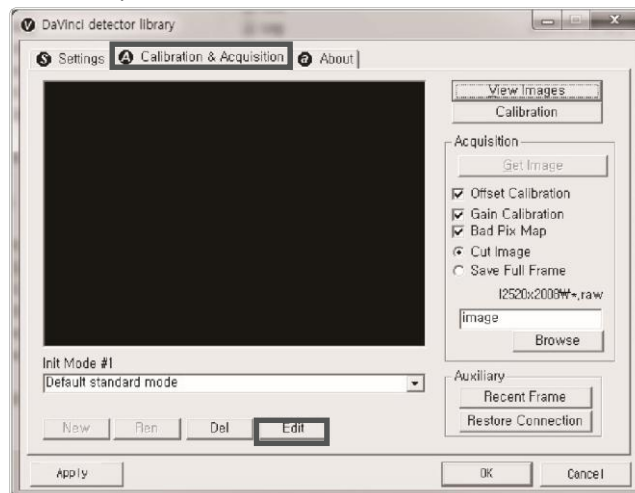

- ③ Click "Edit"
- ④ "Change "Auto Trigger Threshold" from 5 to 100 and click "OK"

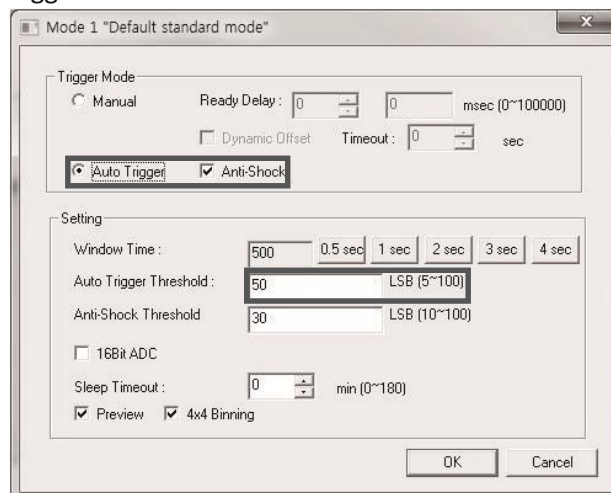

#The Auto Trigger Threshold default values are 50 for Csl models and 30 for GdOS models.



753 ITECO,150 Jojeong-Daero, Hanam-Si, Gyeonggi-do, Korea 465736

Tel: +82-31-790-0647 Fax: +82-31-790-0604

E-mail: service@sghealthcare.com

www.sghealthcare.com