

Mẫu nội dung nhãn phụ:

Kim lùn tĩnh mạch không cánh, không cổng

Chủng loại: BD Angiocath™ I.V. Catheter for Special Placement

Mã sản phẩm: 382259

Số lưu hành:

Số lô: Xem “**LOT**” trên nhãn gốc.

Hạn sử dụng: Xem “” trên nhãn gốc.

Tên/ Địa chỉ chủ sở hữu trang thiết bị y tế: Becton Dickinson Infusion Therapy Systems Inc./
9450 South State Street, Sandy, Utah 84070, Mỹ.

Tên/ Địa chỉ cơ sở sản xuất: Becton Dickinson Infusion Therapy Systems Inc. S.A. de C.V./
Periferico Luis Donaldo Colosio#579, Nogales, Sonora, C.P.84048, Mexico.

Xuất xứ: Mexico.

Tên/ Địa chỉ chủ sở hữu số lưu hành: Văn phòng đại diện Becton Dickinson Asia Limited
tại TP. Hồ Chí Minh/ Phòng 1106-07, tầng 11, toà nhà Mê Linh Point, số 2 Ngô Đức Kế,
Phường Sài Gòn, thành phố Hồ Chí Minh.

Tên/ Địa chỉ đơn vị nhập khẩu & phân phối:

Tên/ Địa chỉ cơ sở bảo hành: Thiết bị y tế sử dụng một lần, không có chế độ bảo hành.

Cảnh báo, hướng dẫn sử dụng, hướng dẫn bảo quản: Xem trong *Hướng dẫn sử dụng* đính
kèm HOẶC trên *Bao bì sản phẩm* HOẶC Website: <https://eifu.bd.com>

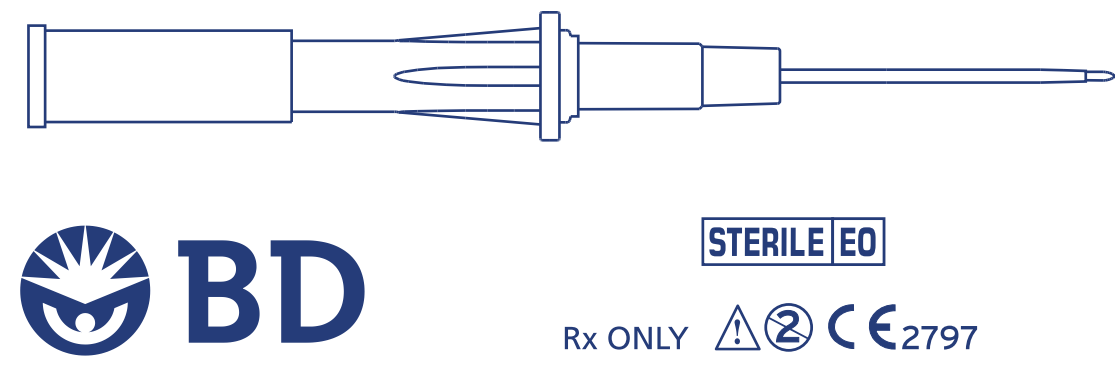

Rx ONLY 2797

50

FEP Polymer
50

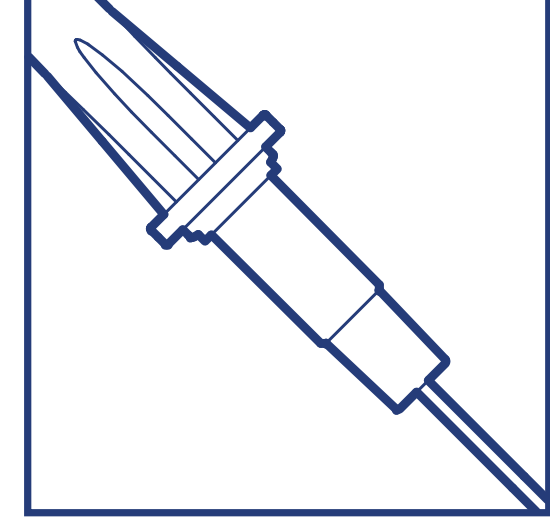
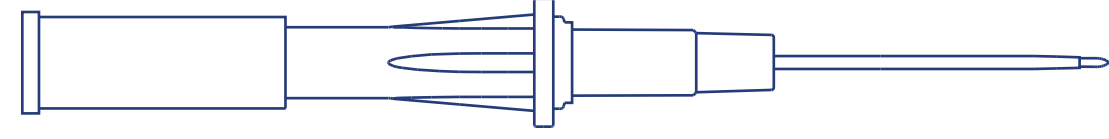

特殊用途用靜脈留置カテーテル
一次生使用靜脈留置針

50

Rx ONLY 2797



BD AngiocathTM

I.V. Catheter for Special Placement
Catéter I.V. para colocación especial
Cateter I.V. para colocação especial
Catheter IV pour placement special
i.v. Katheter für spezielle Punktionen
Catetere e.v. collocazione speciale
I.V. catheter voor speciale plaatsing
I.V.-kateter for særskild placering
I.V. kateter for særlig anbringelse
特殊用途用靜脈留置カテーテル
一次生使用靜脈留置針

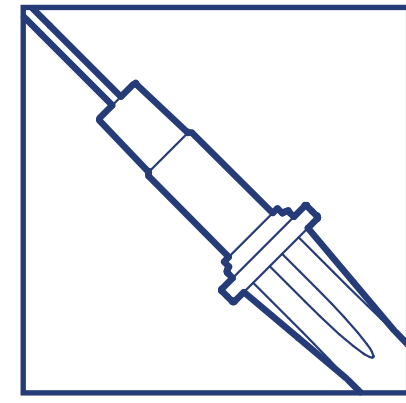

BD AngiocathTM

FEP Polymer

I.V. Catheter for Special Placement
Catéter I.V. para colocación especial
Cateter I.V. para colocação especial
Catheter IV pour placement special
i.v. Katheter für spezielle Punktionen
Catetere e.v. collocazione speciale
I.V. catheter voor speciale plaatsing
I.V.-kateter for særskild placering
I.V. kateter for særlig anbringelse
特殊用途用靜脈留置カテーテル
一次生使用靜脈留置針

50

Radiopaque, Nonpyrogenic.
Radiopaco, Apirogénico.
Radiopaco, Apirogénico.
Radio-Opaque, Apyrogene.
Röntgenfåhig, Pyrogenfri.
Radiopaco, Apirogeno
Radiopaak, Pyrogeenvrij.
Röntgentåt, Pyrogenfri
Röntgenfast, Pyrogen fri.
X線不透過、非発熱性、
射線透不過的、無熱原質的

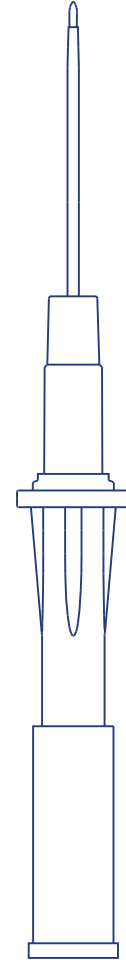

F3450-3

Becton Dickinson Infusion Therapy Systems Inc., 9450 South State Street, Sandy, Utah 84070, USA
 BD Distribution Centre, Laagstraat 57, B-9140 Ternse, Belgium
 Becton Dickinson Industrias Cirúrgicas Ltda Avenida Presidente Juscelino Kubitschek, 273, Francisco Bernardino - Juiz de Fora - MG
Brazil 36081-000
 Becton Dickinson Korea Ltd., 5th & 6th Floor, Im Sung Building, 788-2, Yoksam-Dong, Kangnam-Ku, Seoul 135-080, Republic of
Korea
 Becton Dickinson India Private Limited, The Surya, Best Western Hotel, E Floor, New Friends Colony, New Delhi, 110 065, India
 Becton Dickinson Argentina S.R.L., Montenegro 1402, Cdad. Autónoma de Buenos Aires, Argentina
 Becton Dickinson Pty Ltd., 4 Research Park Drive, Macquarie University Research Park, North Ryde NSW 2113 Australia
 Becton Dickinson de Mexico, S.A. de C.V., Monte Pelvoux III 8° Piso, Lomas de Chapultepec, 11000 Mexico, D.F.
 Becton Dickinson Philippines, Inc., 29F, The Discovery Center, #25 ADB Avenue, Ortigas Center, Pasig City
 Becton Dickinson Canada Inc., 2100 Derry Road West, Suite 100, Mississauga, ON L5N 0B5
 Becton Dickinson & Company, Singapore branch, 30 Tuas Avenue 2, Singapore, 639461
 Becton Dickinson Ltd 8 Pacific Rise Mt Wellington, Auckland New Zealand
製造販売元：日本ベクトン・ディッキンソン（株） 福島県福島市土船字五反田1番地 16200BZY1149000

BD, BD Logo and BD Angiocath are trademarks of Becton, Dickinson and Company. © 2019 BD.

50

Rx ONLY 2797

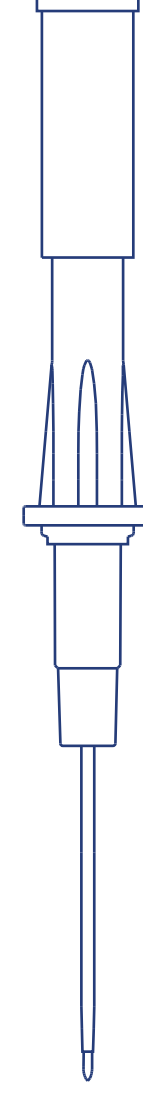

REF **382259**

Angiocath

16 GA 5.25 IN

1.7 x 133 mm

PRODUCT OF MEXICO

D12345-2 (07-15)



(17)YYMMDD(10)YJJSSS(30)50



(01)50382903822596

 YYYY-MM-DD

PRODUCT OF MEXICO

LOT YJJSSS

D12345-2 (07-15)



(17)YYMMDD(10)YJJSSS(30)10

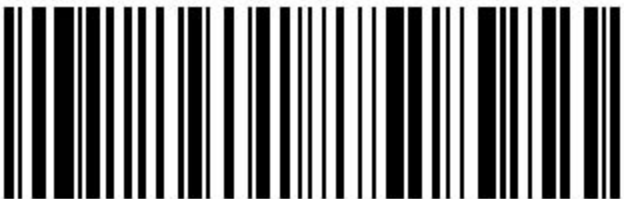

(01)30382903822592

 YYYY-MM-DD

LOT YJJSSS

PRODUCT OF MEXICO

D12329-3 (07-15)

Angiocath

REF 382259

16 GA 5.25 IN
1.7 X 133 mm
108 ml/min.



BD Angiocath™

STERILE EO CE 2797 Rx ONLY

- Radiopaque, Nonpyrogenic. Potentially Hazardous Device. Read directions and precautions for use and disposal on package insert.
- Radiopaco, Apirogénico. Dispositivo potencialmente peligroso. Lea las instrucciones y precauciones indicadas en el prospecto para uso y desecho.
- Radiopaco, Apirogenico. Dispositivo potencialmente perigoso. Leia as instruções e advertências incluídas no pacote quanto ao uso e descarte.
- Radio-Opaque, Apirogene. Instrument potentiellement dangereux. Lire les instructions et les précautions indiquées sur la notice pour le mode d'emploi et l'élimination.
- Röntgenfähig, Pyrogenfrei. Potentiell gesundheitsgefährdendes Instrument. Bitte Gebrauchsanleitung und Warnhinweise zur Verwendung und Entsorgung in der Packungsbeilage beachten.
- Radiopaco, Apirogeno. Strumento potenzialmente pericoloso. Leggere nel foglietto allegato le istruzioni per le modalità d'uso e d'eliminazione.
- Radiopaak, Pyrogeenvrij. Potentieel gevaarlijk instrument. Lees voor gebruik en wegwerpen de aanwijzingen en voorzorgsmaatregelen op bijsluiter.
- Röntgentät, Pyrogenfri. Eventuellt en farlig anordning. Läs instruktioner och varningar om användning och kassering på förpackning-sinlägget.
- Röntgenfast, Pyrogen fri. Potentielt farligt redskab. Læs anvisninger og forholdsregler vedr. brug og bortskaffelse i dispenser.
- X線不透過、非発熱性。危険性のあるデバイス。包装添付 説明書の 使用指示および廃棄に関する注意をお読みください。
- 射線透過的、無熱原質的、有潛在危險的設備。請閱讀包裝內所附使用與棄置說明及注意事項。



BD, BD Logo and BD Angiocath are trademarks of Becton, Dickinson and Company. © 2019 BD.

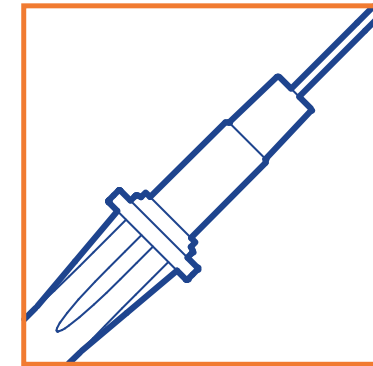

BD Angiocath™

I.V. Catheter for Special Placement
 Catéter I.V. para colocación especial
 Cateter I.V. para colocação especial
 Cathéter IV pour placement spécial
 i.v. Katheter für spezielle Punktionen
 Catetere e.v. colocazione speciale
 I.V. kateter voor speciale plaatsing
 I.V. kateter för särskild placering
 I.V. kateter for særlig anbringeelse
 特殊用途用靜脈留置力テール
 一次性使用靜脈留置針

FEP Polymer

10

Becton Dickinson Infusion Therapy Systems Inc., 9450 South State Street, Sandy, Utah 84070, USA
 Becton Dickinson Distribution Centre, Laagstraat 57, B-9140 Temse, Belgium
 Becton Dickinson Industrias Cirúrgicas Ltda Avenida Presidente Juscelino Kubitschek, 273, Francisco Bernardino - Juiz de Fora - MG Brazil 36081-000
 Becton Dickinson Korea Ltd., 5th & 6th Floor, Im Sung Building, 788-2, Yoksam-Dong, Kangnam-Ku, Seoul 135-080, Republic of Korea
 Becton Dickinson India Private Limited, The Surya, Best Western Hotel, E Floor, New Friends Colony, New Delhi, 110 065, India
 Becton Dickinson Argentina S.R.L., Montenegro 1402, Ciudad Autónoma de Buenos Aires, Argentina
 Becton Dickinson Pty Ltd, 4 Research Park Drive, Macquarie University Research Park, North Ryde NSW 2113 Australia
 Becton Dickinson de Mexico, S.A. de C.V., Monte Pelvoux III 8° Piso, Lomas de Chapultepec, 11000 Mexico, D.F.

Becton Dickinson Philippines, Inc., 29F, The Discovery Center, #25 ADB Avenue, Ortigas Center, Pasig City
 Becton Dickinson Canada Inc., 2100 Derry Road West, Suite 100, Mississauga, ON L5N 0B5
 Becton Dickinson & Company, Singapore Branch, 30 Tuas Avenue 2, Singapore, 639461
 Becton Dickinson Ltd 8 Pacific Rise Mt Wellington, Auckland New Zealand
 製造販売元：日本ベクトン・ディッキンソン（株） 福島県福島市主幹字五反田1番地
 162008ZY01149000



• I.V. Catheter for Special Placement • Catéter I.V. para colocación especial • Cateter I.V. para colocação especial • Cathéter IV pour placement spécial • i.v. Katheter für spezielle Punktionen • Catetere e.v. collocazione speciale • I.V. catheter voor speciale plaatsing • 特殊用途用靜脈留置カテーテル • 一次性使用靜脈留置針

Becton Dickinson Infusion Therapy Systems Inc.,
9450 S State St, Sandy, Utah 84070



REF 382259

16 GA 5.25 IN
1.7 x 133 mm

108 ml/min

Product of Mexico, H3243-6

Rx ONLY



STERILE EO

FEP Polymer

Radiopaque, Nonpyrogenic
Radiopaco, Apirógeno
Radiopaco, Apirogenico
Radio-Opaque, Apirogene
Röntgenfähig, Pyrogenfrei
Radiopaco, Apirogeno
Radiopaak, Pyrogeenvrij
X線不透過、非發熱性
射線透不過的，無熱原質的

Document: H3243

Valid From: 18-Dec-2024 To: 31-Dec-9999

Print Date: 05-Nov-2025 21:53:10 GMT Standard Time

Doc Type: ZLB

Doc Part: EN

Usage: Production Usage

Status: Released EFFECTIVE

Revision: 06

Version: D

Change #: 500000360473

Classification: Restricted

REVISION HISTORY			
REV	DESCRIPTION	AUTHOR	ECO NO
9	UPDATED THE SHEET TO THE LATEST TEMPLATE. ADDED VARIABLE PRINT FORMAT AND A NOTE 2 RELATED TO THE LATEST HUMAN READABLE TEXT. UNIT LABEL NOTE MODIFIED TO INCLUDE BARCODE, HRI, GTIN, EXPIRY INPUTS. GTIN NUMBER ADDED TO TABLE 1. NOTE 1 PROCEDURE CPR-070 REPLACED WITH LATEST PROCEDURE GTS-50007.	EDWIN JEYASEELAN A	500000360473
8	ADDED TABLE-2 IN THE DRAWING	MOHAMMED ZIAUDDIN	500000265931
7	CHANGED MATERIAL THICKNESS CPK FROM 0.63 TO 1.0. CHANGED SEAL WIDTH CPK FROM 1.03 TO 1.0.	LIV GHECIU	ECO155126

DISPENSER LABEL WRAPS AROUND FROM TOP TO END

DISPENSER CONTAINS 10 INDIVIDUAL UNIT PACKAGES WITHOUT SPECIFIC ORIENTATION

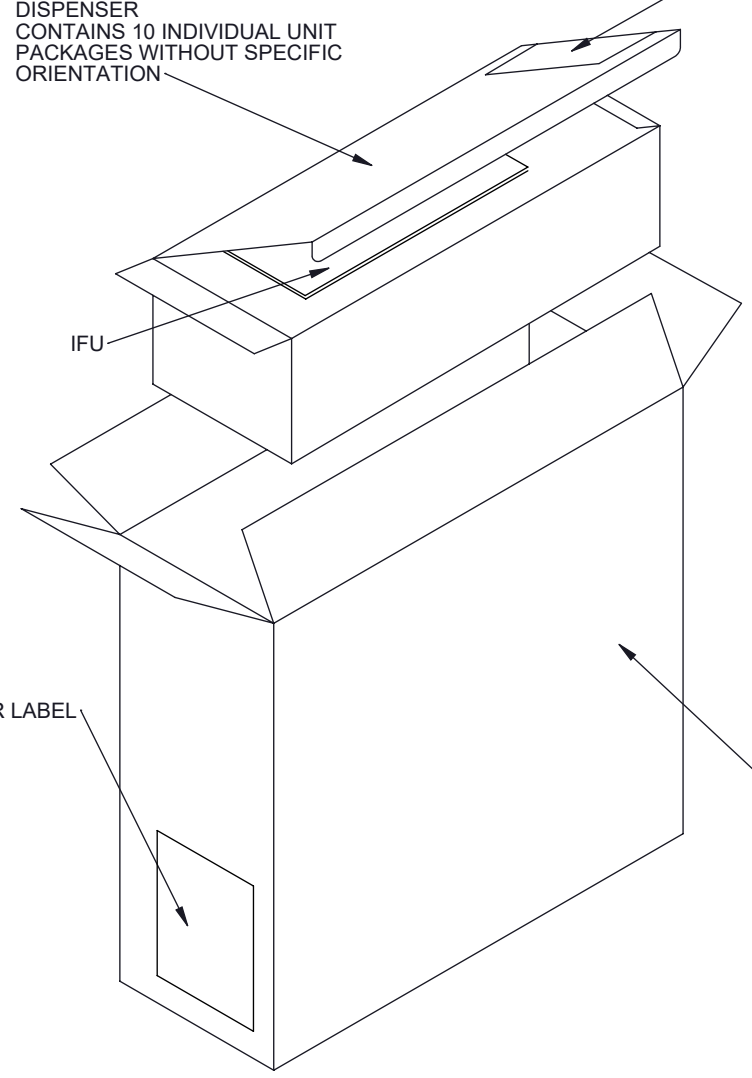

DISPENSER LABEL WRAPS AROUND FROM TOP TO END

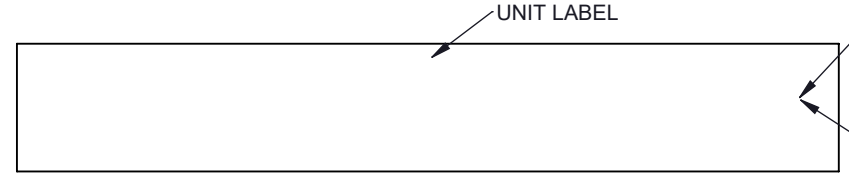

UNIT LABEL

BARCODE AND HUMAN READABLE TEXT - GTIN, EXPIRE SYMBOL, EXPIRE DATE, LOT SYMBOL, LOT NUMBER, MANUFACTURING SYMBOL AND DATE PRINTED ON THE ADHESIVE SIDE IN THE PEEL TAB AREA

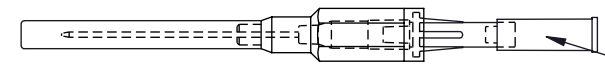

ANGIOCATH SPECIAL FINAL ASSEMBLY

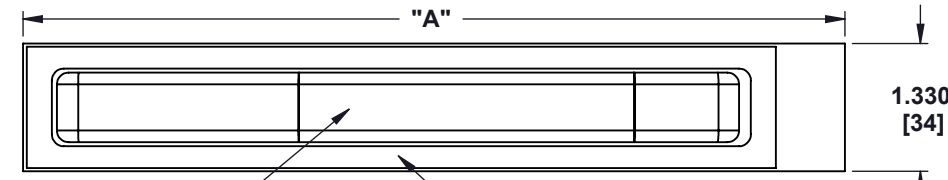

MINIMUM SEAL WIDTH OVERALL: SEE TABLE-2

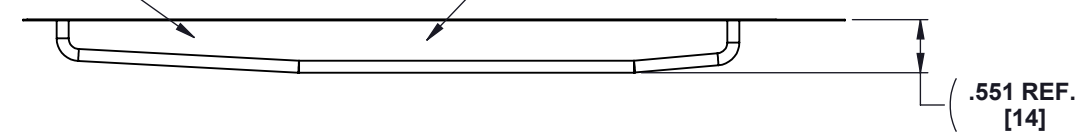

MINIMUM MATERIAL THICKNESS OVERALL: SEE TABLE-2

VARIABLE PRINT FORMAT

(01)XXXXXXXXXXXXXX
(17)YYMMDD
(10)1234567

YYYY-MM-DD YYYY-MM-DD

LOT 1234567

- NOTE:
- MINIMUM SAMPLE SIZE FOR SEAL STRENGTH, SEAL WIDTH AND BOTTOM WEB THICKNESS IS N=100 FOR Ppk=0.64. FOR SAMPLE SIZES REFER TO GTS-50007 TABLE-3.
 - The GTIN code shall be followed by (17)YYMMDD (10)1234567 as shown in the above variable information format. Horizontal or vertical printing accommodation is allowed.

TABLE-1

CATALOG NUMBER	DESCRIPTION	"A" DIMENSION		GTIN
		INCH	MM	
382258	ANGIOCATH SPECIAL GRAY 16GA X 3.25IN	8.583	218	(01)00382903822584
382259	ANGIOCATH SPECIAL GRAY 16GA X 5.25IN	10.157	258	(01)00382903822591
382268	ANGIOCATH SPECIAL ORN 14GA X 3.25IN	8.583	218	(01)00382903822683
382269	ANGIOCATH SPECIAL ORN 14GA X 5.25IN	10.157	258	(01)00382903822690
382277	ANGIOCATH SPECIAL LGT BL 12GA X 3.0IN	8.583	218	(01)00382903822775
382287	ANGIOCATH SPECIAL TAN 10GA X 3.0IN	8.583	218	(01)00382803822874

TABLE-2 PACKAGING MATERIAL AND SPECIFICATIONS

SKU	Material Combination	Minimum seal strength Min PpK 0.64 and 95%CI	Minimum seal width Min PpK 0.64 and 95%CI	Minimum Bottom web thickness Min PpK 0.64 and 95%CI
382258 382277 382287 382268	PS75 sealed to Bemis 36615 6.0 mil PS55 sealed to Berry 2106 8.0 mil	0.59 lb/in	0.09 inches	0.0006 inches
382269 382259	PS75 sealed to Bemis 36615 6.0 mil PS55 sealed to Berry 2106 8.0 mil	0.52 lb/in 0.4807 lb/in	0.09 inches 0.08 inches	0.0005 inches 0.0007 inches

BD Medical
9450 South State Street
Sandy, Utah 84070 USA

© 2023 BD. THIS MATERIAL IS CONFIDENTIAL AND PROPRIETARY PROPERTY OF BECTON, DICKINSON AND COMPANY. NO PORTION MAY BE USED, REPRODUCED OR DISTRIBUTED WITHOUT PRIOR WRITTEN PERMISSION.

TITLE: PKG ASSY, ANGIOCATH SPECIAL PRODUCTS

DEFAULT TOLERANCES .XX = ± .01 .XXX = ± .005 .XXXX = ± .0005 ANGLE = ± 1° FRACT = ± 1/64 UNLESS OTHERWISE SPECIFIED	DESIGN AUTHOR S. BROWN CREATION DATE 12/15/1986 MODIFICATION DATE 23 Aug 2024 PART FILE NAME 401506	UNITS INCHES UNLESS OTHERWISE SPECIFIED SCALE DO NOT SCALE DO NOT MEASURE FROM PRINT	SHEET 1 OF 1 DRAWING NUMBER 401506
---	--	---	--

PDM MODEL REV: M02SAP PDM SHEET REV: D09SAP