



HbA1c 501

Analyzer



EN
DE
NL
SV
DA
NO
PT

Operating Manual

TABLE OF CONTENTS

EN

1. INTENDED PURPOSE	2
2. INTENDED USER	2
3. GENERAL INFORMATION	2
4. PRINCIPLES OF OPERATION	3
5. HemoCue® HbA1c 501 Analyzer CONTENTS	4
6. STORAGE INSTRUCTIONS	4
7. DEVICE DESCRIPTION	5
8. LIST OF ICONS	6
9. INSTALLATION	7
10. OPERATION	8
11. ANALYZER SET UP	9
12. RUN a HbA1c TEST	11
13. REVIEWING RESULTS	17
14. SYSTEM CHECK	18
15. OPTIONS	27
16. PRODUCT LIST	32
17. TROUBLESHOOTING	33
18. SPECIFICATION	35
19. MAINTENANCE	35
20. SAFETY	37
21. DISPOSAL	37
22. PRECAUTION	38
23. SYMBOLS & DESCRIPTIONS	40

1. INTENDED PURPOSE

The HemoCue[®] HbA1c 501 Analyzer is a near-patient testing (NPT) in vitro diagnostic (IVD) automated medical device intended for quantitative measurement of hemoglobin A1c (HbA1c). This device is intended for healthcare professionals at hospitals, clinics, and clinical/medical laboratories and must only be used with HemoCue HbA1c 501 Test Cartridge.



Please read through and familiarize yourself with the contents of this operating manual before using the system for the first time.

2. INTENDED USER

Intended user: Healthcare professionals

3. GENERAL INFORMATION

The HemoCue[®] HbA1c 501 system is a small, portable, and fully automated point-of-care system for all healthcare environments. The system delivers rapid results with laboratory equivalent accuracy and precision across all test parameters.

The HemoCue[®] HbA1c 501 system may be used as a basic test system where the user manually records the results, or as an advanced system where accessories enable automatic printing of results, input of patient and operator identification numbers, and full connectivity to a PC. This makes the system highly versatile as it can be tailored to specific user needs.

This manual contains all the information needed to operate and maintain the HemoCue[®] HbA1c 501 system.

4. PRINCIPLES OF OPERATION

The HemoCue® HbA1c 501 system is a fully automated boronate affinity assay for determination of the Hemoglobin A1c percentage (HbA1c %) in whole blood.

The Test Cartridge consists of a cartridge and a reagent pack containing the reagents necessary for the determination of hemoglobin A1c, with a sampling area for blood collection.

The reagent pack is pre-filled with reagent solution and rinsing solution. The reagent solution contains agents that hemolyse erythrocytes and bind hemoglobin specifically as well as a boronate resin that binds to the cis-diols of glycated hemoglobin.

The blood sample (4µL) is collected at the sampling area of the reagent pack, which is then inserted into the cartridge, where the blood is instantly lysed releasing the hemoglobin and the boronate resin binding the glycated hemoglobin.

The reagent pack containing the blood sample is inserted in HemoCue® HbA1c 501 Analyzer (in which the cartridge has been placed). The cartridge is automatically rotated, placing the blood sample in the measuring zone. The total hemoglobin is photometrically measured by the diffused reflectance of the optical sensor composed of both a LED (Light Emitting Diode) and a PD (Photo Diode).

The assembled cartridge is rotated and the rinsing solution washes out non-glycated hemoglobin from the blood sample, enabling photometric measurement of glycated hemoglobin.

The ratio of glycated hemoglobin and total hemoglobin is calculated.

$$\text{HbA1c \%} = A \times \left[\frac{\text{HbA1c}}{\text{Total Hemoglobin}} \times 100 \right] + B$$

Where 'HbA1c' and 'Total Hemoglobin' are the signals obtained from the HemoCue HbA1c 501 system, 'A' and 'B' are the slope and intercept factors to correct the value for the calibration standard of NGSP.

* NGSP: National Glycohemoglobin Standardization Program

5. HemoCue® HbA1c 501 Analyzer CONTENTS

At delivery carefully inspect the product for any obvious physical damage. If any damage is evident, please consult your local distributor.

Contents

1. HemoCue® HbA1c 501 Analyzer



2. Operating Manual



3. Exclusive Power Adapter



4. Fan Filters

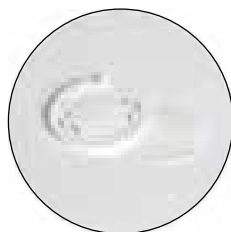

5. Daily Check Cartridge



6. Monthly Check Cartridge

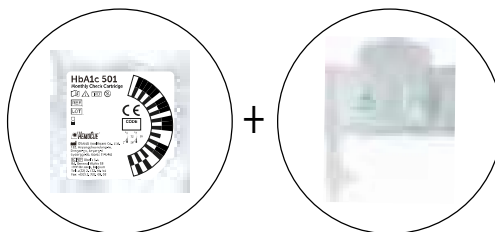

6. STORAGE INSTRUCTIONS

The HemoCue® HbA1c 501 Analyzer must be stored at 10-35°C (50-95°F).

Test Cartridges must be stored at 2-32°C (36-90 °F) and at a relative humidity of 10-90% until expiry date printed on the package.

7. DEVICE DESCRIPTION

EN



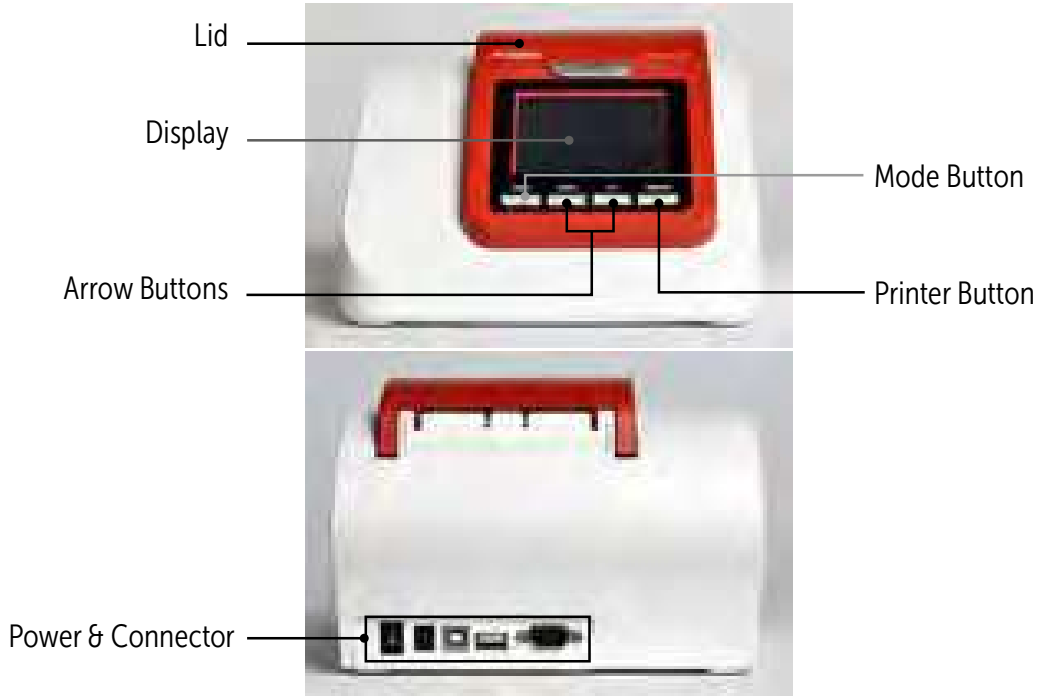



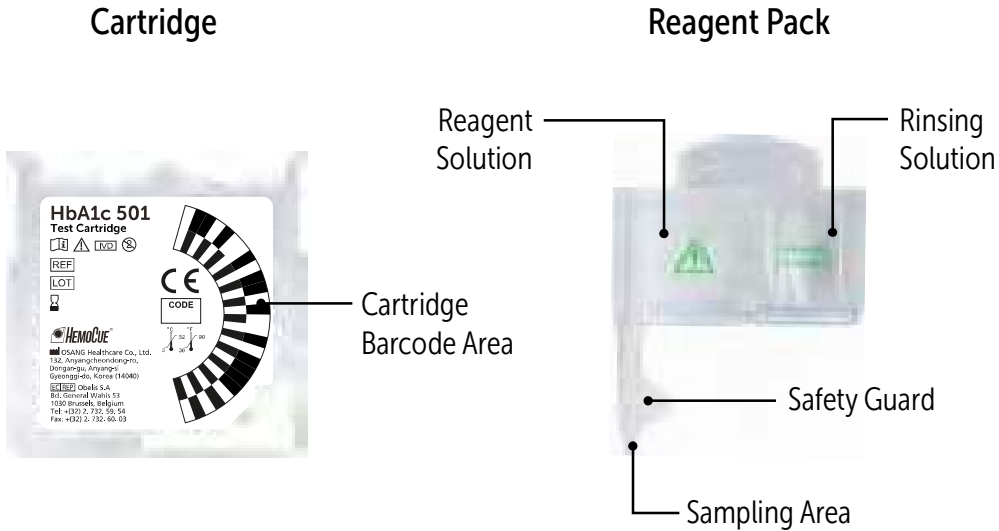



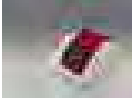

7.1 Analyzer

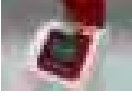
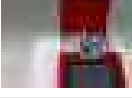
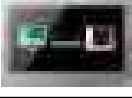

7.2 Test Cartridge

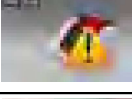

8. LIST OF ICONS

Icon	Name	Function
	Warming up	Displayed on the analyzer when turned on.
	Open the lid	Open the lid of the analyzer.
	Monthly Check Mode	Display Monthly Check mode on Analyzer.
	Daily Check Mode	Display Daily Check mode on Analyzer.
	Insert Cartridge	Insert Cartridge into the analyzer.
	Filling sample to Sampling area	Fill blood sample to Sampling area of reagent pack.
	Insert Reagent Pack	Insert reagent pack with blood sample into the analyzer.
	Close the lid	Close the lid of the analyzer.
	Remove cartridge	Remove the cartridge from the analyzer.
	PC Connection	The analyzer is connected to a PC.
	Printer	The thermal printer use is active.
	Memory	View saved test results.
	Set up	Select this icon to set up the analyzer.
	Tilt or move warning	Analyzer is tilted in Standby mode. Reinstall on flat surface.
	Tilt or move warning	Movement or Tilting was detected during the measurement. Discard the cartridge and retest a new cartridge.

9. INSTALLATION

Overview

This section provides detailed installation instructions for the HemoCue® HbA1c 501 Analyzer. The installation steps must be followed correctly to ensure proper installation, operation, and service.



Always handle the analyzer with care.

Do not drop or misuse. The calibrated optics, electronics or other internal parts may be disrupted or damaged.

Do not expose the HemoCue® HbA1c 501 Analyzer to extreme temperature variations.

Avoid open windows, direct sunlight, ovens, hot plates, open burners, radiators and dry ice baths.

Place the HemoCue® HbA1c 501 Analyzer on a rigid surface, free from any vibration.

Unpack the Analyzer

Your HemoCue® HbA1c 501 Analyzer is delivered in a shipping carton.

1. Carefully remove the contents from the shipping carton.
2. Inspect the carton and analyzer for any visible damage.
3. Make sure that all items are included.
4. If any damages is found or parts are missing, contact your local distributor.

Installing Connections

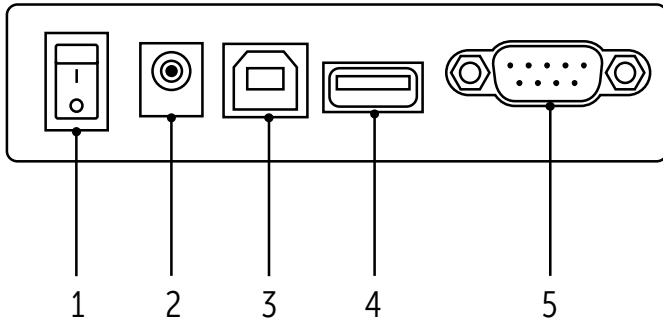

Analyzer Connections:

1. Power Button
2. DC 9 V adaptor port
3. USB port
4. Barcode Scanner port
5. Thermal Printer port & PC Connection Port (RS 232)

Power connection

1. Ensure that the analyzer power button is off and the lid is closed.
2. Connect the power adaptor to the analyzer (port 2) to appropriate grounded AC electrical outlet.

10. OPERATION

10.1 Power On

On/Off 9V USB Barcode Printer

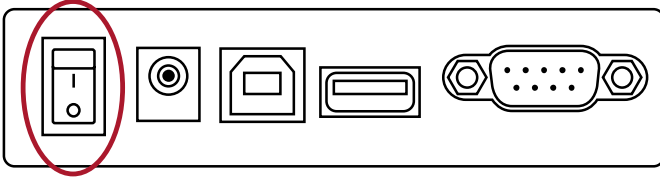

After proper installation, start the HemoCue® HbA1c 501 Analyzer by turning the power switch "ON".



If the lid is open, the icon "Close the lid" is displayed.

Close the lid - warming up will start.



If the cartridge is inserted, the icon "Take out the cartridge" is displayed.

Take out the cartridge and close the lid.

Warming up will start.

10.2 Warm up

When the power is connected, the display will show 'Warming up' until the device is ready for use.

Warming up will take approximately 5 minutes depending on the ambient temperature.



While warming up, the HemoCue® HbA1c 501 Analyzer performs hardware functionality test to verify that the internal optics and the mechanical system are operating correctly.

10. OPERATION

10.3 Stand-by



After warming, the Analyzer switches to 'Stand-by' mode.

10.4 Power Save





After 30 minutes in 'stand-by' mode, without action, the Analyzer switches to 'Power Save' mode.

To return to 'Stand-by' mode, press  quickly, or open the lid for testing.

11. ANALYZER SET UP



Getting into set up mode





In stand-by mode, press the  button and hold for 3 seconds. Choose between set up and data mode by pressing  or  button. Press  button to select. Choose set-up mode.

Date





Select the date format ('yy/mm/dd' or 'mm/dd/yy' or 'dd/mm/yy') by pressing  or , press .

Next, set the date by pressing  or  button.

Hold the arrow keys to scroll through the dates faster.

Time





Select the time format by pressing the  or  button, then press . 12h for standard time / 24h for military time.

11. ANALYZER SET UP

HbA1c test result unit



Select HbA1c test unit by pressing the  or , then press .

[NGSP]

[IFCC]





Barcode use



Select to use the barcode system or not by pressing  or , then press .



Printer use



Select to use the printer or not by pressing  or , then press . If 'Use' is selected, Printer mode option is displayed.

Printer mode



After printer option is selected, choose 'Automatic' or 'Manual' by pressing the  or .

- Automatic: Result is printed automatically after each test.
- Manual: Result will only be printed when print button is pressed.

12. RUN a HbA1c TEST

Procedure

Blood Sample

The HemoCue® HbA1c 501 test can be performed on a capillary blood sample or on venous whole blood collected using K2EDTA, lithium heparin, sodium citrate or sodium fluoride/oxalate as an anticoagulant.

Preparation

STEP 1.

When the power is connected, the display will show 'Warming up' until the device is ready for use.

This will take approximately 5 minutes depending on the ambient temperature.



 Do not move the Analyzer during 'Warming up'.

STEP 2.

Open the lid of the HemoCue® HbA1c 501 Analyzer, when the 'Open the lid' icon is shown.



STEP 3.

Open the cartridge package by tearing the pouch on the side with the serrated edge.

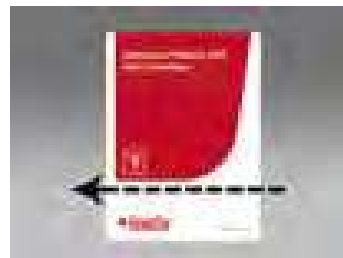

12. RUN a HbA1c TEST

 When handling the reagent pack and cartridge, do not touch the cartridge code area on the front or the bead window at the back. Any contamination of these areas may cause erroneous values.

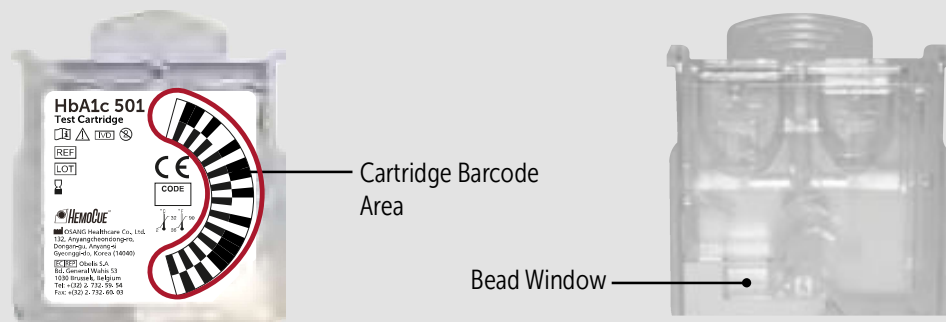

Procedure

STEP 1.

Carefully insert the cartridge into the cartridge compartment when the 'Insert Cartridge' icon is displayed. Hold the cartridge with barcode facing left. Ensure gentle snap is heard or felt to confirm proper placement.



 The cartridge is designed to only fit in one way. Do not force it in. After inserting the empty cartridge into the analyzer, begin the measurement within 5 minutes.

12. RUN a HbA1c TEST

STEP 2-1.

Gently mix by turning the reagent pack back and forth 5 - 6 times before applying blood sample.

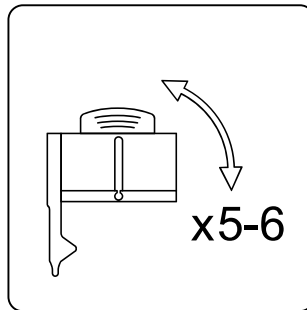

Capillary whole blood from fingertip and venous whole blood can be used for HbA1c test. 4 μ L capillary whole blood from fingertip or venous whole blood is needed for HbA1c testing.

STEP 2-2.

Apply the blood sample by gently touching the drop of blood with the tip of the sampling area. Ensure that the sampling area is completely filled.

Sample Collection and Handling

- Use of Capillary Blood

Puncture the fingertip to get a minimum of 4 μ L of capillary blood sample. Gently touch the blood sample with the tip of the sampling area of the Reagent Pack. The blood is automatically drawn in via capillary action.

Ensure that the sampling area is completely filled.

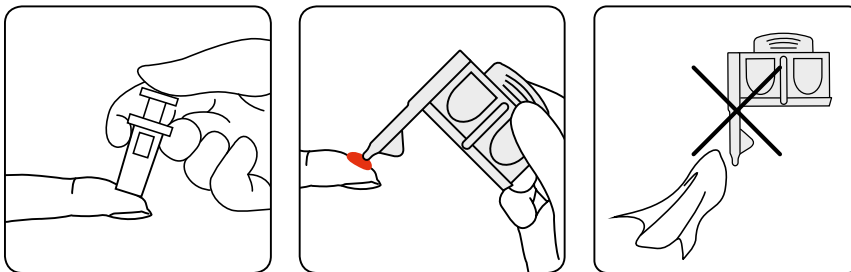

12. RUN a HbA1c TEST

Reagent pack sampling area

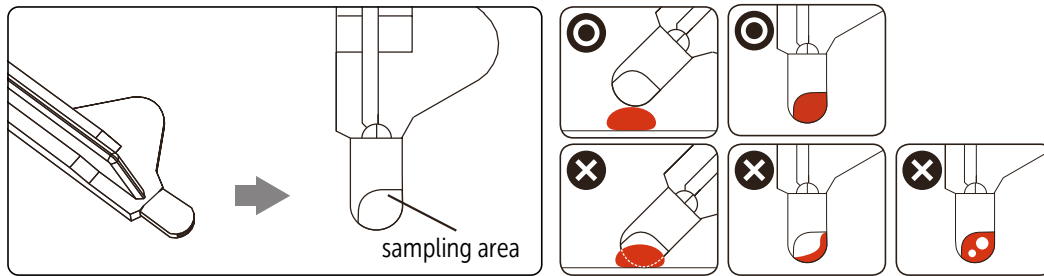

Use of Venous Blood

Venous whole blood collected in tubes with K2EDTA, lithium heparin, sodium citrate or sodium fluoride/oxalate as an anticoagulant can be used.

Venous whole blood can be stored at 2-8°C for 7 seven days with unbroken seal (only 3 days when seal is broken) and at 20-25°C for 3 days.

Mix the tube thoroughly prior to testing. Open the lid and take out one drop of blood with a pipette. Place a drop of blood on a hydrophobic surface. Gently touch the drop of blood with the tip of the sampling area of the reagent pack. Ensure that the sampling area is completely filled.

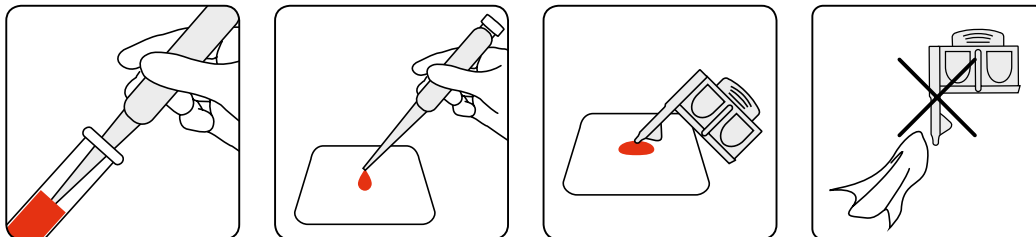

i Do not wipe off excess blood outside the sampling area.
Do not touch the open end of the sampling area.

i There is a potential risk of biological hazard.
All parts of the HemoCue® HbA1c 501 System should be considered potentially infectious.

- Use gloves
- Dispose used test cartridges in a sturdy container with lid
- Consult local environmental authorities for proper disinfection procedures as well as disposal of consumables

12. RUN a HbA1c TEST

STEP 3.

Insert the reagent pack in the cartridge and gently push into cartridge compartment of the analyzer. The icon 'Close the lid' will be displayed.



 Do not force the reagent pack into the cartridge, it will only fit one way.

STEP 4.

The test starts automatically when the lid is closed.

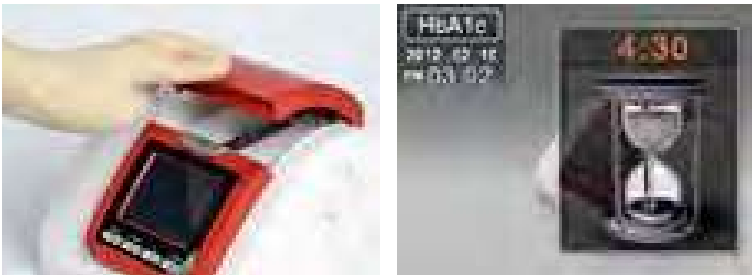

 Do not open the lid during testing.
Do not move the analyzer during testing.
Do not expose the analyzer to vibration during testing.

STEP 5.

The HbA1c result displays after 5 minutes.

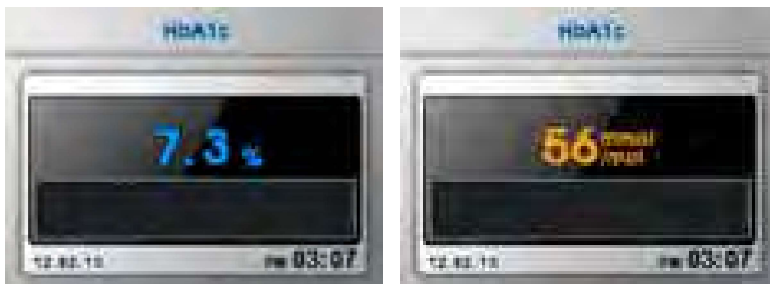



12. RUN a HbA1c TEST

 If the results ">14%" or "<4%" are displayed repeat testing to confirm result. For IFCC (mmol/mol) unit, please refer to unit settings in the instructions.

STEP 6.

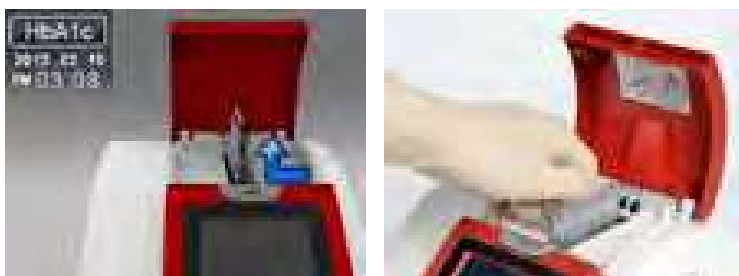
After the test is completed, open the analyzer lid. The display will show 'Remove Cartridge'. Take out the cartridge from the analyzer by gently pushing it to the left and pulling it out.





 Do not force the cartridge to remove it from the analyzer. Dispose all waste in accordance with applicable national and/or local regulations.



Code confirmation display after testing

If an error in the cartridge code recognition process occurs, the analyzer will ask for type and code of the cartridge.



1. Take out the cartridge, use  and  to match the type of cartridge, press  to confirm.



2. After selecting the type of cartridge, use  and  to match the code number of the cartridge, press  to confirm, and the test result is shown.

12. RUN a HbA1c TEST

Expected values

ADA's most recent Clinical Practice Recommendation for diabetes specifies a treatment goal of less than 7.0 HbA1c %, 53 mmol/mol.

[Reference]

The American Diabetes Association's (ADA's) 2012 Clinical Practice Recommendation for diabetes specifies a treatment goal of less than 7 HbA1c %, 53 mmol/mol.







Limitation of Procedure

The HemoCue® HbA1c 501 assay gives accurate and precise hemoglobin results in the range 7 to 20 g/dL. Most patients will have hemoglobin concentrations within this range.

However, patients with severe anemia may have hemoglobin concentrations below 7 g/dL, and patients with polycythemia may have hemoglobin concentrations above 20 g/dL. Patients known to have these conditions should be tested with another method for determination of HbA1c%.



13. REVIEWING RESULTS

STEP 1.

In stand-by mode, press  button for 3 seconds for  or . Press  or  button to select Data, then press .



STEP 2.

The test results will appear chronologically starting with the most recent date. Press  and  buttons to scroll through the test results.



14. SYSTEM CHECK

Quality Control

The HemoCue® HbA1c 501 Check Cartridge screens the optical and operating systems of the Analyzer.

Type of Check Cartridges

- HemoCue® HbA1c 501 Daily Check Cartridge
- HemoCue® HbA1c 501 Monthly Check Cartridge

Storage Instruction

The Check Cartridges must be protected from sunlight during storage;

- Store the Check Cartridge at 2 - 32°C (36 -90°F) and humidity < 90%
- Always store the Check Cartridge in its protective packaging to prevent scratches which may affect the result.
- If the Check Cartridge is refrigerated, allow to reach room temperature before use. (~1 hour).

Precautions/Warnings

- For *In Vitro* Diagnostic Use.
- Do not use the Check Cartridge beyond the expiration date.
- Do not use the Check Cartridge if stored incorrectly or if it is dirty, scratched or damaged.

Daily Check Cartridge



When to Use the Daily Check Cartridge

- Once a day before samples are tested.
- After moving the analyzer.
- After an error message. (Er 1 or Er 3)

The Daily Check Cartridge consists of a cartridge without a reagent pack (packed in a pouch).

Life-time: Until stated expiration date printed on the cartridge label.

14. SYSTEM CHECK

EN



- Store the Daily Check Cartridge in its original package when not in use.
- The Daily Check Cartridge can be purchased separately from your local distributor.



How to use the Daily Check Cartridge

1) Open the lid of the HemoCue® HbA1c 501 Analyzer.



2) Press  to enter Daily Check Cartridge mode.



3) Insert Daily Check Cartridge while 'Daily Check' is displayed.

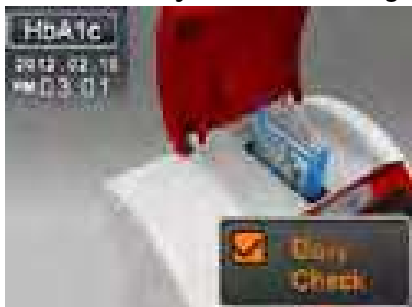

14. SYSTEM CHECK

4) Close the lid. The test starts automatically.



5) After 1 minute 'OK' or 'Er 2' will be displayed.



6) After test completion, take out the cartridge.



- If an error message is displayed, repeat the test.
- Do not use the analyzer if the error persists.
- To leave Daily Check mode, press  .

14. SYSTEM CHECK

Monthly Check Cartridge



Monthly Check Reagent Pack

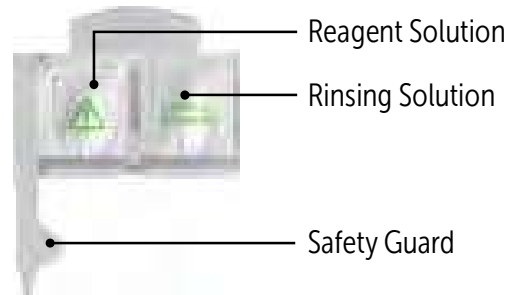

EN

When to Use the Monthly Check Cartridge

- Once a month before samples are tested.
- On suspicion that test results may be incorrect.
- After an error message (Er 4 or Er 5).

The Monthly Check Cartridge, used to check the Analyzer, consists of a cartridge and a reagent pack, same as the test cartridge, but without the sampling area.



- Do not reuse.
- Do not use Monthly Check Cartridge after expiration date.



- If Monthly Check Cartridges are reused, the analyzer will display 'Er 14 (Do not reuse)'
- The Monthly Check Cartridge can be purchased from your local distributor.

How to use the Monthly Check Cartridge

1) Open the lid of the Analyzer.



14. SYSTEM CHECK

2) Press  to enter Monthly Check Cartridge mode.



3) Insert the Monthly Check Cartridge while 'Monthly CHECK' is displayed.



4) Gently mix the reagent pack by turning it back and forth 5 - 6 times before use.

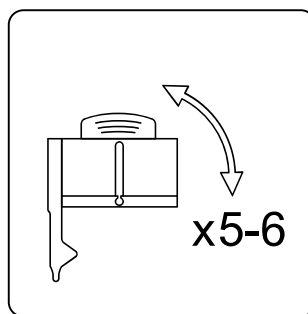

14. SYSTEM CHECK

5) Carefully Insert the Monthly Check Reagent Pack, when 'Insert reagent pack' is shown.



6) Close the lid. The test starts automatically.



- Do not open the analyzer lid during testing.
- Do not move the analyzer during testing.
- Do not expose the analyzer to vibration during testing.

7) After 5 minutes 'OK' or error message will be displayed.



14. SYSTEM CHECK

8) Remove cartridge when the test is completed.



- If an error message is displayed, repeat the test.
- Do not use the analyzer if an error message persists.
- Contact your local distributor for support.
- To leave Monthly Check Cartridge mode, press .

Quality Control - External control material

The system can be verified according to local guidelines using a commercially available HbA1c control.

If required, the verification is recommended in connection with installation or when training a new operator.

Recommended control solutions are, level 1 and level 2 of Lyphochek[®] Diabetes Control from Bio-rad or CueSee[®] HbA1c from Eurotrol.

Only human whole blood controls can be used with the HemoCue[®] HbA1c 501 system. Contact your local distributor for technical support.

How to test with the Control Solution

1) Open the lid of the analyzer.



2) Insert the cartridge when 'Insert Cartridge' is displayed.

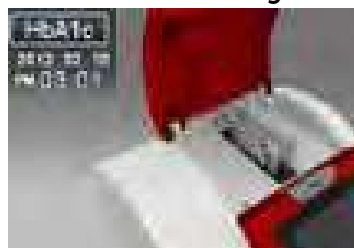

14. SYSTEM CHECK

3) Mix the reagent pack gently 5-6 times and touch the control solution with the tip of the sampling area. The control solution is automatically drawn up into the sampling area. Wait until the sampling area is completely filled with control solution.

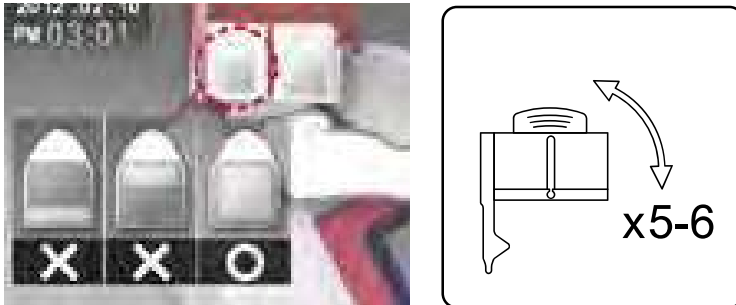

4) Insert the reagent pack into the cartridge compartment of the analyzer.

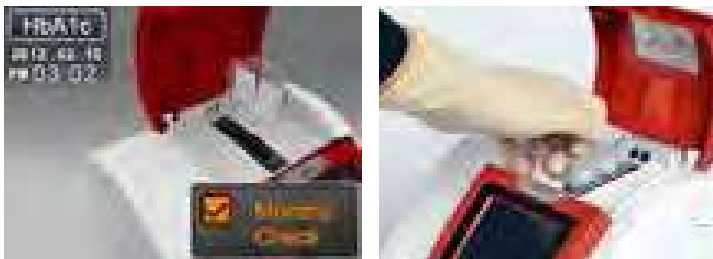

⚠ Do not contaminate the sampling area of the reagent pack.

5) Close the lid. The test starts automatically.



14. SYSTEM CHECK



- Do not open the analyzer lid during testing.
- Do not move the analyzer during testing.
- Do not expose the analyzer to vibration during testing.

6) The test result is displayed after 5 minutes.

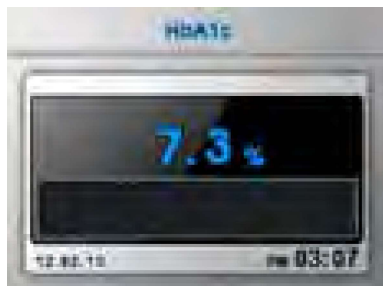

The test result should be within the target range specified on the package insert of the control solution.

7) Take out the cartridge after the test is completed.

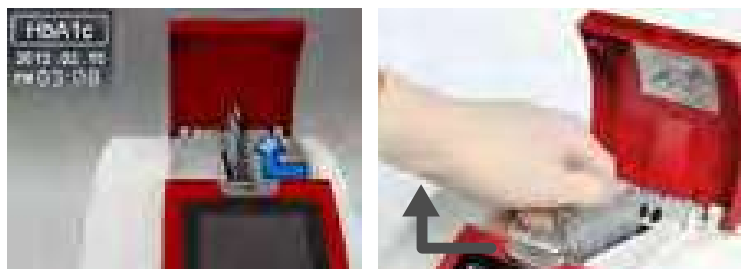

- Deterioration of the cartridge due to high humidity, heat, or overexposure to light.
- Deterioration of the control solution.



- Repeat the QC test using a fresh cartridge from a new box or new lot. If the result still is out of range, proceed to next possible cause.
- Repeat the QC test with a fresh bottle of control solution.
- Contact your local distributor for support.

15. OPTIONS

15.1 Printer

Below are the items included in the standard printer package. If any items are damaged or missing, please contact your local distributor.

Martel printer



Paper roll

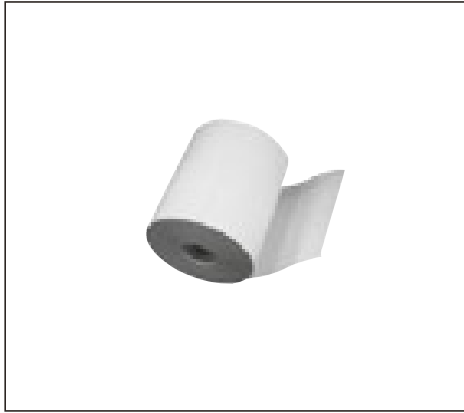

AC-DC adaptor



Printer cable (RS-232C)

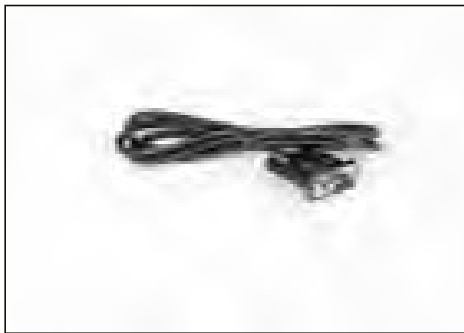

Installation

Read and follow the manufacturer's instructions for use.

Connect the thermal printer to the analyzer with the printer cable (RS-232C).

The analyzer should be in stand-by mode.

15. OPTIONS

Printing Test Results with the Thermal Printer

Connect the thermal printer to the analyzer with the printer cable (RS-232C).
The analyzer should be in stand-by mode.

On/Off 9V USB Barcode Printer

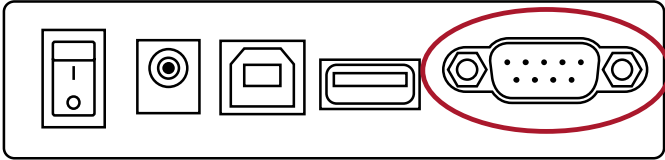

The printer is already pre-set to manual or automatic printing. See page 9.

- **Automatic:** Prints automatically after each test.
- **Manual:** Prints only when printer button is pressed.

Printer in manual mode

STEP 1. Press printer button after the result is displayed.



STEP 2. The display will show 'Current' and 'ALL'

STEP 3. Press  or , to select - press .



- **Current:** Only chosen result will be printed.
- **ALL:** All results in memory will be printed.

15. OPTIONS

EN

Specifications

Printing system	Direct thermal line head
Max Characters per line	24, 32 or 48
Character font	Arial 16, 24 CPL, Arial 12, 32 CPL Arial 8, 48 CPL
Average printing speed	10 lines per second (max)
Dimensions	85.5 mm x 150 mm x 55 mm (45 mm low profile printer)
Weight	400 g approx. (inc batteries and paper)
Internal power supply	4 x 1.2 V NiMH 1600 mAH, AA cells
Paper width	58 mm
Paper capacity	25 m (std printer),10 m (low profile printer)

Interface	
Data format	RS232C
Connector	6-way RJ12 socket

Above specifications may change without notice from supplier.
Please ask for technical specifications before purchase. For further information and technical support please contact your local distributor.

15. OPTIONS

15.2 Scanner

The HemoCue[®] HbA1c 501 Analyzer accepts data input from the following barcode standards

Code 93 standard including check digit
Code 39 with optional check digit required
Code 128 standard including check digit
CodaBar without check digit



Activate use of barcoding system by a pre-set process (page 9).

The barcode scanner can be used to scan patient ID and operator ID.
Scanned information is stored in the analyzer for future reference.

On/Off 9V USB Barcode Printer

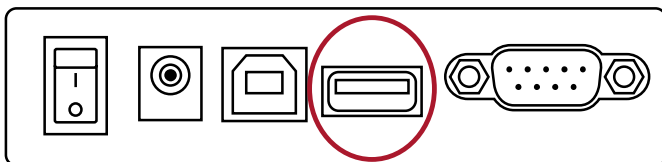

When performing test using barcode system

STEP 1. Open the lid of HemoCue[®]
HbA1c 501 analyzer

STEP 2. Insert the cartridge when
'Cartridge insert' is displayed.

STEP 3. The display shows 'Patient ID'
and 'Operator ID'.



STEP 4. Scan the Patient ID barcode.



STEP 5. Scan the Operator ID barcode.



15. OPTIONS



It is important that the labels are printed under correct conditions.

Reading errors may occur if:

- The width of the barcode is too narrow
- The barcode length is too long
- The barcode height is too low
- The reader is held too far from the label
- The background reflection is too high or low

Contact your local distributor for support.

15.3 Transfer Test Results to a Computer

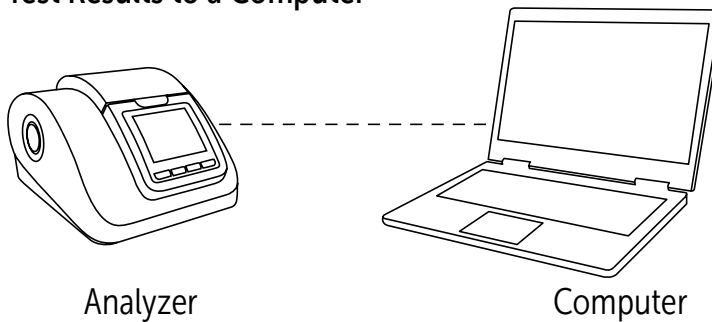

Analyzer

Computer

STEP 1. Connect the RS-232 cable from the analyzer to the computer whilst in stand-by mode. RS-232 cable are not included in the set. Please contact your local distributor and purchase them separately.

On/Off 9V USB Barcode Printer/PC

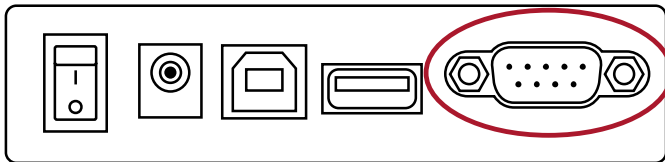

STEP 2. Once connected, the analyzer will display 'PC'.

STEP 3. Download the PC application program. PC application program are not included in the set. Please contact your local distributor for support.

STEP 4. Once the program is downloaded, click 'Data Transfer' icon on the computer. Results will be transferred from analyzer to computer.



- Ensure that the security patches for the PC are updated to keep your cyber assets safe.
- Measurement cannot be made in PC mode.
- Data received from the meter do not include personal information other than the HbA1c measurement result.
- If a dedicated data cable is not used, the communication may be affected by the electromagnetic field and cause malfunction.

16. PRODUCT LIST

Components



ITEM	CONTENTS
HemoCue® HbA1c 501 Analyzer	Analyzer (1EA) Operating Manual (1EA) Exclusive Power Adapter (1EA) Daily Check Cartridge (1EA) Monthly Check Cartridge (1EA)
Optional Products	
Test Cartridges Monthly Check Cartridges Daily Check Cartridge	10 Cartridges/box 6 Cartridges/box 1 Cartridge/package
Thermal printer Printer cable	
Barcode scanner	Purchased separately
PC Software PC Cable	
Fan Filter	5 fan filters/package

17. TROUBLESHOOTING



EN

General Information

If an operational or system problem occurs, an error code is displayed explaining the problem. This section of the guide lists the various errors and messages, along with descriptions and corrective actions. If the problem persists, record the error code and contact your local distributor for technical support.

ERROR CODE	DESCRIPTION	CORRECTIVE ACTION
Er 1 (Er1-1 to Er1-8)	Problem with the analyzer system	Turn power switch off and on again. If the problem persists contact your local distributor. Use Daily Check to confirm the analyzer performance.
Er 2 (Er2-1 to Er2-5)	Check cartridge error	Check cartridge may be damaged (bar code label, reagent pack or contaminated surface). Insert a new Check cartridge and perform a new test.
Er 3	Problem with reading bar code of cartridge	Press  button and remove the cartridge. Use the daily check to confirm the analyzer performance. Insert a new cartridge. If 'reagent pack' is displayed, the test can be started. If the error persists, contact your local distributor.
Er 4	Test cartridge error	The coding area of the Test cartridge may be damaged or contaminated. Press  button and remove cartridge. Use Monthly Check to verify the analyzer performance. Insert a new Test cartridge and perform a new test.
Er 5	Reagent pack problem	The analyzer is unable to recognize the reagents (in the reagent pack). The reagent pack may be damaged or leaking. Press  button and remove the cartridge. Use Monthly Check to verify the analyzer performance. Insert a new Test cartridge and perform a new test.
Er 6	Time out	Insert a new cartridge and perform a new test within 5 minutes.

17. TROUBLESHOOTING

ERROR CODE	DESCRIPTION	CORRECTIVE ACTION
Er 7	The lid was opened during test/check	Press  button and remove the cartridge. Insert a new cartridge and perform a new test.
Er 14 (Do not re-use)	An already used Test cartridge or Monthly Check cartridge is used (may occur when re-using Monthly Check cartridge)	Press  button and remove the cartridge. Insert a new cartridge and perform a new test.
Lo°C	The ambient temperature is too low	Ensure the equipment is within normal operating temperatures for at least 10 minutes. Insert a new cartridge and perform a new test.
Hi°C	The ambient temperature is too high	Ensure the equipment is within normal operating temperatures for at least 10 minutes. Insert a new cartridge and perform a new test.
<4%	The HbA1c test result is lower than 4.0% (20mmol/mol)	Use the Daily Check cartridge to confirm the analyzer performance. Insert a new cartridge and perform a new test.
>14%	The HbA1c test result is higher than 14.0% (130mmol/mol)	Use the Daily Check cartridge to confirm the analyzer performance. Insert a new cartridge and perform a new test.
The Analyzer does not start	There is a problem with the power adaptor or the analyzer itself	Unplug the power adaptor and reconnect. If the problem still persists, contact your local distributor.
Caution Analyzer has moved	The analyzer has been moved or is detected to tilt during the measurement.	Move to a flat stable surface. Discard the cartridge and insert a new cartridge and perform a new test.

18. SPECIFICATION

EN

Sample Type	Capillary whole blood, Venous whole blood with anticoagulant
Sample Volume	4 µL
Test Range	4.0-14.0%(NGSP), 20-130mmol/mol(IFCC)
Reading Time	5 minutes
Memory Capacity	1000 test results
Wavelength	415 nm
Power Required	DC 9 V-2 A
Dimensions/Weight	198*217*136(mm) / 1.6kg
Storage Temperature Analyzer	10 ~ 35°C (50 ~ 95°F)
Operating Temperature	17 ~ 32°C (63 ~ 90°F)
Relative Humidity Range	10% ~ 90%
Options	Print support – connection to Thermal Printer for printing support. Barcode scanner for scanning of patient ID operator ID. PC application for transfer of data to computer.

19. MAINTENANCE

Recommended maintenance routine

- 1) Exterior cleaning of the analyzer
- 2) Cartridge compartment cleaning
- 3) Replacing air filter

19. MAINTENANCE

Cleaning the analyzer

- 1) Disconnect the analyzer before cleaning.
- 2) Wipe off the Analyzer using a soft, clean cloth.
- 3) Do not use liquid or aerosol cleaners.
- 4) If necessary, an alcohol swab can be used to remove dirt, other chemical solutions should not be used. Cleaning solutions may cause damage to the analyzer surface.

Cleaning the cartridge compartment of the analyzer

STEP 1. Turn the power off and disconnect the power cord before cleaning.

STEP 2. When the lid is opened, press the two black knobs to rotate the cartridge compartment forward.



STEP 3. Moisten a sponge with ethanol or recommended commercial disinfectant (Recommended disinfectants: CaviCide[®], METREX[®] RESEARCH COPORATION, US)

STEP 4. Gently wipe off the cartridge compartment using the sponge. Do not to drip any liquids into the system.

Replacing the Fan Filter:

Regularly check the fan filters located on the back of the analyzer. Replace the fan filter if clogged by dust. Extra filters are included at delivery of the analyzer.



Filter cover

STEP 1. Remove the fan filter cover.

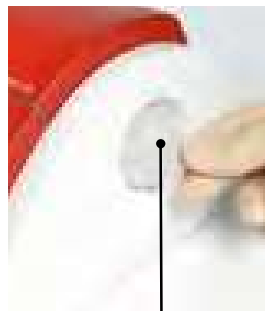

Filter

STEP 2. Take out the used fan filter - replace with a new.

STEP 3. Close the cover.

NOTE: Additional fan filters can be purchased from your local distributor.

20. SAFETY

The analyzer has been fully tested according to the Electrical Safety Regulations (EN 61010-2-101).

EN

SAFETY TIPS

- 1) Do not disassemble the analyzer.
- 2) Do not expose analyzer to high humidity.
- 3) Do not expose analyzer to pollution or dust.
- 4) Do not expose analyzer to any impact, shock, or vibration.
- 5) Do not place analyzer next to chemical products.
- 6) Keep away from direct sun light.
- 7) Do not cover ventilation openings on the back of the analyzer.
- 8) Do not touch the analyzer with any metallic or inflammable materials.
- 9) Do not install analyzer near any potential electromagnetic sources.
- 10) In case of any serious incident occurs from using device, report to the manufacturer and the competent authority of the Member state in which the user and/or the patient is established.

21. DISPOSAL

The analyzer must be disposed of according to the local regulations concerning the disposal of electrical and electronic equipment.

The Waste Electrical and Electronic Equipment (WEEE) regulation implements provisions of the European Parliament and Council Directive 2012/19/EC aimed at reducing the amount of EEE waste going for final disposal.

The manufacturer has specific instructions for the recovery of the analyzer. Please contact your distributor.

22. PRECAUTION

1. Place the analyzer a flat and rigid surface.
2. Electric power should be stable.
3. Analyzer and Cartridge are not to be exposed to direct sunlight.
4. Follow the indicated Analyzer operating temperature (17 - 32°C) and Cartridge storage temperature (2 - 32°C).
5. Do not move or interfere with the analyzer during testing.
6. The bead inside the Reagent Solution of the Reagent Pack, might sink and coagulate. Gently mix the Reagent Pack before testing, and visually check that the beads are not coagulated.
7. Allow the test cartridge to reach room temperature (ambient temperature) 30 minutes before use.
8. When collecting blood, touch the end of the capillary tip (sampling area) to the blood sample, do not put the tip deep into the blood sample to avoid excess blood.

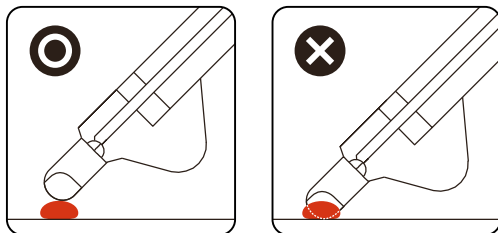

9. Ensure that the cartridge compartment is empty before inserting the cartridge.
10. Insert the Cartridge gently in the Analyzer.
11. Firmly insert the reagent pack into cartridge with a mild pressure until a snap is heard or felt. Too much force may affect the mixture of the two reagents resulting in an incorrect result.



22. PRECAUTION

EN

12. After the test is completed remove the cartridge and inspect the cartridge for symptoms (below). If a symptom is observed, repeat the test to conform the validity of the result.

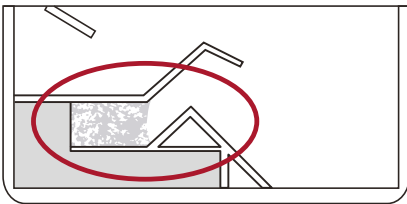
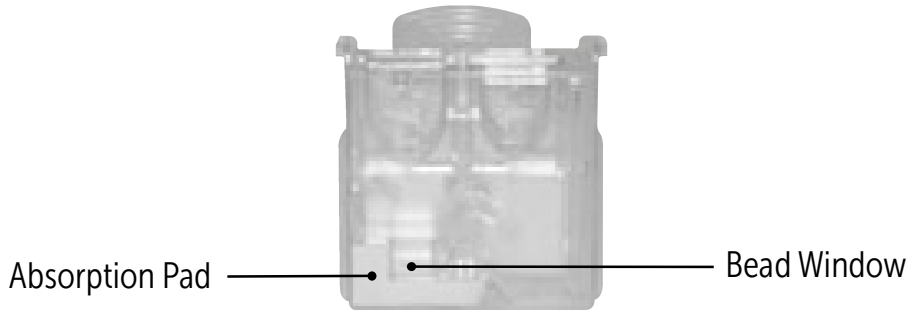

1) The bead window is not uniformly colored.

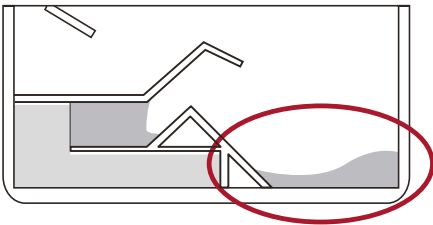

2) Reagent is left in the cartridge and not fully absorbed by Absorption Pad.

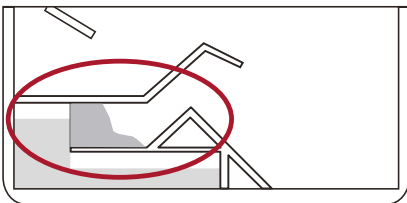



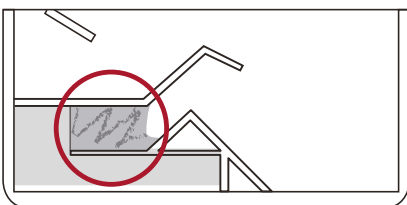







3) The bead window is only partly full.



4) The bead window appears contaminated or scratched.









13. Follow the instructions in the trouble shooting guide when an error occurs.

23. SYMBOLS & DESCRIPTIONS

Symbol	Description
	European Conformity
	Consult instructions for use
	Use-by date
	Caution
	Authorized representative in the European Community/ European Union
	<i>In vitro</i> diagnostic medical device
	Batch code
	Catalogue number
	Serial number
	Manufacturer

23. SYMBOLS & DESCRIPTIONS

EN

Symbol	Description
	Temperature limit
	Near-Patient Testing
	Keep away from sunlight
	Direct Current
	Waste Electrical and Electronic Equipment
	Biological risks
	Model number
	Distributor
	Do not re-use