

Instructions to User

Dear users, thank you very much for purchasing the device.

This Manual is written and compiled in accordance with the council directive MDD93/42/EEC for medical devices and harmonized standards. In case of modifications and software upgrades, the information contained in this document is subject to change without notice.

The Manual describes, in accordance with the device's features and requirements, main structure, functions, specifications, correct methods for transportation, installation, usage, operation, repair, maintenance and storage, etc. As well as the safety procedures to protect both the user and equipment. Refer to the respective chapters for details.

Please read the User Manual carefully before using this product. The User Manual which describes the operating procedures should be followed strictly. Failure to follow the User Manual may cause measure abnormality, equipment damage and human injury. The manufacturer is NOT responsible for the safety, reliability and performance issues and any monitoring abnormality, human injury and equipment damage due to users' negligence of the operation instructions. The manufacturer's warranty service does not cover such faults.

Owing to the forthcoming renovation, the specific products you received may not be totally in accordance with the description of this User Manual. We would sincerely regret for that.

This product is medical device, which can be used repeatedly.

WARNING:

- ☛ **Uncomfortable or painful feeling may appear if using the device ceaselessly, especially for the microcirculation barrier patients. It is recommended that the device should not be applied to the same finger for over 2 hours.**
- ☛ **For the special patients, there should be a more prudent inspecting in the placing process. The device can not be clipped on the edema and tender tissue.**
- ☛ **The light (the infrared is invisible) emitted from the device is harmful to the eyes, so the user and the maintenance man should not stare at the light.**
- ☛ **Testee can not use enamel or other makeup.**
- ☛ **Testee's fingernail can not be too long.**
- ☛ **Please refer to the correlative literature about the clinical restrictions and caution.**
- ☛ **This device is not intended for treatment.**

The User Manual is published by our company. All rights reserved.

Contents

1	Safety	1
1.1	Instructions for Safe Operation	1
1.2	Warning	1
1.3	Attention	2
1.4	EMC Statement	2
2	Overview	3
2.1	Features	3
2.2	Major Applications and Scope of Application	3
2.3	Contraindications	3
3	Principle	4
4	Technical Specifications	4
4.1	Main Performance	4
4.2	Main Parameters	5
4.3	Environment Requirements	5
5	Installation	6
5.1	View of the Front Panel	6
5.2	View of the Back Panel	7
5.3	Accessories	7
6	Operating Guide	8
6.1	Application Method	8
6.2	Attention for Operation	15
6.3	Clinical Restrictions	16
7	Maintenance,Transportation and Storage	17
7.1	Cleaning and Disinfecting	17
7.2	Maintenance	17
7.3	Transportation and Storage	17
8	Troubleshooting	18
9	Key of Symbols	19
10	Function Specification	21
11	Factory Default	22
	Appendix I	23

1 Safety

1.1 Instructions for Safe Operation

- ✧ Check the main unit and all accessories periodically to make sure that there is no visible damage that may affect patient's safety and monitoring performance. It is recommended that the device should be inspected weekly at least. When there is obvious damage, stop using the device.
- ✧ Necessary maintenance must be performed by qualified service engineers ONLY. Users are not permitted to maintain it by themselves.
- ✧ If the battery has to be replaced, the battery shall be provided by manufacture and replaced only by trained service personnel. Incorrect replacement and model of battery may cause device damage and patient injury.
- ✧ The device can't be used together with devices not specified in User Manual. Only the accessory that is appointed or recommendatory by manufacture can be used with this device.
- ✧ This product is calibrated before leaving factory.
- ✧ Users should have basic text distinguish ability.
- ✧ The patient is also an intended operator. Patient can use the device for measurement, storage and data upload. While device maintenance, clean or batteries replacement is not allowed.
- ✧ During normal use, please do not position this device to make it difficult to disconnect from power supply.
- ✧ After use, please switch off and unplug the device.

1.2 Warning

- ⚠ Don't open the enclosure of the device to avoid tip-and-run danger. Necessary maintenance and upgrade must be performed by qualified service engineers who have been trained and accredited by our company ONLY
- ⚠ Explosive hazard—DO NOT use the device in the environment with tinder such as anesthetic .
- ⚠ DO NOT use the device while the patient is being scanned by MRI or CT.
- ⚠ The disposal of scrap instrument and its accessories and packing (including battery, plastic bags, foams and paper boxes) should follow the local laws and regulations, and place them in the place where the children can't reach.
- ⚠ Please check the packing before use to make sure the device and accessories are totally in accordance with the packing list, or else the device may have the possibility of working abnormally.
- ⚠ Please choose the accessories and probe which are approved or manufactured by the manufacturer, or else it may damage the device.
- ⚠ The device can only be matched with the compatible probe.
- ⚠ Please don't measure this device with functional tester for the device's related information.

⚠ Parts of this device are not allowed to be serviced or maintained while in use with the patient.

1.3 Attention

- ⚠ Keep the device away from dust, vibration, corrosive substances, tinder, high temperature and moisture.
- ⚠ If the device gets wet, please stop operating it.
- ⚠ When it is carried from cold environment to warm or humid environment, please do not use it immediately.
- ⚠ DO NOT operate keys on front panel with sharp materials.
- ⚠ High temperature or high pressure steam disinfection of the device is not permitted. Refer to User Manual in the relative chapter (7.1) for instructions of cleaning and disinfection.
- ⚠ DO NOT have the device immersed in liquid. When it needs cleaning, please wipe its surface with medical alcohol by soft material. Do not spray any liquid on the device directly.
- ⚠ When cleaning the device with water, the temperature should be lower than 60°C.
- ⚠ The fingers which are too thin or too cold may affect the measure accuracy, please clip the thicker finger such as thumb and middle finger deeply enough into the probe.
- ⚠ The device can be used to adult and child. Whether the device is used to adult or children, it depends on the probe selected.
- ⚠ The update period of data is less than 5 seconds, which is changeable according to different individual pulse rate.
- ⚠ Please read the measure value when the waveform on screen is equably and steady-going. This measure value is optimal value, and the waveform at the moment is the standard one.
- ⚠ If some abnormal conditions appear on the screen during test process, pull out the finger and reinsert to restore normal use.
- ⚠ The device has life for three years.
- ⚠ The device has alarm function, users can check on this function according to chapter 6.1 as reference.
- ⚠ The device has the function of limit alarm. When the measure data is beyond limit, the device would start to alarm automatically if the alarm function is on.
- ⚠ The device has alarm function. This function can either be paused, or closed for good. Please check the chapter 6.1 as reference.
- ⚠ The device may not work for all patients. If you are unable to achieve stable readings, discontinue use.

1.4 EMC Statement

Electromagnetic compatibility shall be considered during device in use, because high electromagnetic portable or mobile RF equipment will interfere the working of the device.

Usage of other cables will affect the EMC performance of the device, please use the standard accessories.

2 Overview

The pulse oxygen saturation is the percentage of HbO₂ in the total Hb in the blood, so-called the O₂ concentration in the blood. It is an important bio-parameter for the respiration. A number of diseases relating to respiratory system may cause the decrease of SpO₂ in the blood, furthermore, some other causes such as the malfunction of human body's self-adjustment, damages during surgery, and the injuries caused by some medical checkup would also lead to the difficulty of oxygen supply in human body, and the corresponding symptoms would appear as a consequence, such as vertigo, impotence, vomit etc. Serious symptoms might bring danger to human's life. Therefore, prompt information of patients' SpO₂ is of great help for the doctor to discover the potential danger, and is of great importance in the clinical medical field.

The device is fashion and portable. It is only necessary for patient to put one finger into probe for diagnosis, and display screen will directly show the measure value of pulse oxygen saturation with the high veracity and repetition.

2.1 Features

A Operation is simple and convenient.

B Product is handsome and fashion, and easy to observe

C With two kinds of power supply mode (alternating current and internal electrical power source)

2.2 Major Applications and Scope of Application

The device can be used in measuring the pulse oxygen saturation and pulse rate through finger. The product is suitable for being used in family, hospital, oxygen bar, community healthcare, physical care in sports (It can be used before or after doing sports and it is not recommended to use the device during the process of having sport) and etc.

2.3 Contraindications

 **The problem of overrating would emerge when the patient is suffering from toxicosis which caused by carbon monoxide, and the device is not recommended to be used under this circumstance.**

 **The person who is allergic to rubber can not use this device.**

3 Principle

Principle of the Oximeter is as follows: An experience formula of data process is established taking use of Lambert Beer Law according to Spectrum Absorption Characteristics of Reductive Hemoglobin (Hb) and Oxyhemoglobin (HbO₂) in glow & near-infrared zones. Operation principle of the device is: Photoelectric Oxyhemoglobin Inspection Technology is adopted in accordance with Capacity Pulse Scanning & Recording Technology, so that two beams of different wavelength of lights can be focused onto human nail tip through perspective clamp finger-type sensor. Then measured signal can be obtained by a photosensitive element, information acquired through which will be shown on screen through treatment in electronic circuits and microprocessor.

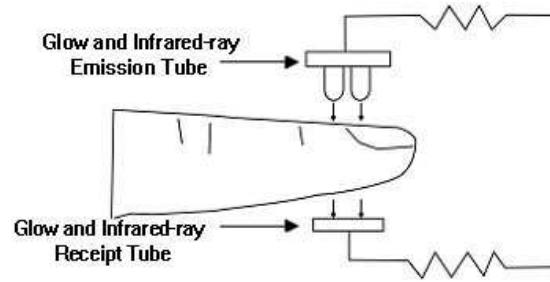

Figure 1.

4 Technical Specifications

4.1 Main Performance

- SpO₂ value display
- Pulse rate value display, bar graph display
- PI value display
- Pulse waveform display
- Battery power display
- Low-power indication: low-power indication symbol appears before working abnormality which is due to low-power.
- Review function
- Screen brightness can be adjusted
- Volume can be adjusted
- Display mode can be adjusted
- Pulse sound indication
- With alarm function, the user could set alarm limit.
- With real-time data uploading function.
- With clock function

- With two kinds of power supply mode(alternating current and internal electrical power source)

4.2 Main Parameters

A Measure of SpO₂

Measure range: 0~100%

Accuracy:

When the SpO₂ measure range is 70%~100%,the permission of absolute error is ±2%;
Below 70% unspecified.

B Measure of pulse rate

Measure range:30bpm~250bpm

Accuracy: ±2 bpm or ±2% (select larger)

C Measure of PI

Range: 0~20%

When the PI measure range is 1%~20%,the permission of absolute error is ±1%

When the PI measure range is 0%~0.9%,the permission of absolute error is ±0.2%;

D Resolution

SpO₂ : 1%

Pulse rate: 1bpm

PI: 0.1%

E Measure performance in weak filling condition:

SpO₂ and pulse rate value can be shown correctly when pulse-filling ratio is 0.4%.

SpO₂ error is ±4%; pulse rate error is ±2 bpm or ±2% (select larger).

F Resistance to surrounding light:

The deviation between the value measured in the condition of man-made light or indoor natural light and that of darkroom is less than ±1%.

G Power supply requirement:

Alternating current supply:100~240V AC 50/60Hz

Internal electrical power source:3.7 V DC ~4.2V DC, use more than 8 hours.

H Optical sensor

Red light (wavelength is 660nm,6.65mW)

Infrared (wavelength is 880nm, 6.75mW)

I Adjustable alarm range:

SpO₂ : 0~100%

Pulse Rate: 0bpm~254bpm

4.3 Environment Requirements

Storage Transportation Environment

- a) Temperature : -40°C~60°C
- b) Relative humidity : ≤95%
- c) Atmospheric pressure : 500hPa~1060hPa

Operating Environment

- a) Temperature:0°C~40°C
- b) Relative Humidity : ≤75%
- c) Atmospheric pressure:700hPa~1060hPa

5 Installation

5.1 View of the Front Panel

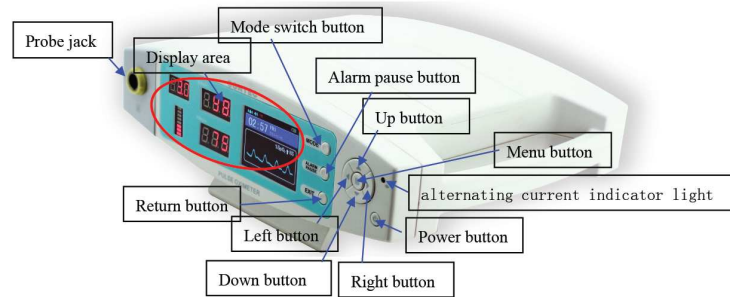

Figure 2. Front view

Alternating current indicator light: the light is green when powered on.

Probe jack : it is used to connect Oximeter probe to measure the oxygen saturation, pulse rate and PI.

Display area: display measure information

Button Area:

1 Mode switch button: click it to switch mode (Measure interface 1 / Measure interface 2)

2 Alarm pause button: when alarm happens, press it to make alarm sound pause. The pause time could be set by menu.

3 Return button: return to the previous menu.

4 Up button / down button / left button / right button: change the choice bar position
left / right button: set part function

5 Menu button: in waveform measure interface, press the button to enter the menu setting; in menu interface, press the button to enter the corresponding submenu.

6 Power button: in power-off state, long press the button to turn on the device; in power-on state, long press the button to turn off the device.

5.2 View of the Back Panel

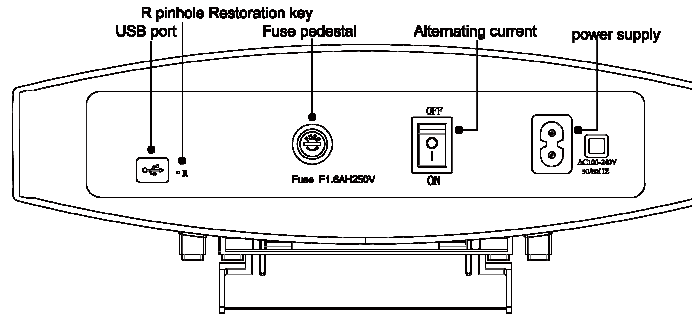

Figure 3. Back view

USB port :It is used to connect computer to transmit data by data line.

R pinhole Restoration key:restore the device.

The computer intended to be connected with this device,shall be approved and certificated according to IEC 60950.

⚠ During data transmitting,please do not use this device with patient.

Alternating current switch :switch power supply between alternating current and direct current.

Fuse pedestal:equipped with a high votage fuse (T1.6AH250V, Maximum current 1.6A, rated voltage 250V)

Power supply jack:power supply line interface

5.3 Accessories

A A User Manual

B A power supply line(2M,unmask,Kun Shan Hong Shen Chuan Electrical Wiring Co.,Ltd.,HSC401+HSC405)

C A data line(1M,unmask,contec,HGP0034)

D A disk (PC software <SpO₂ Assistant>)

E An Oximeter probe(1.5M,unmask,contec,ESA0008)

Optional:

A Other Oximeter probe (refer to <Probe Application Introduction>)

6 Operating Guide

6.1 Application Method

6.1.1

Inserting the lemo probe into the lemo jack of the device (The probe is limited to the one that is provided by our company; and can't be replaced with the similar one by other manufacturers),then put the finger into the probe as Figure 4.

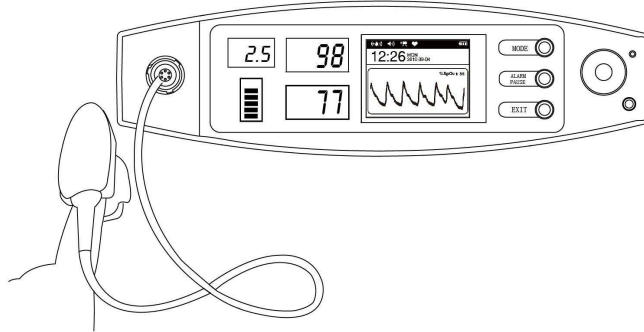

Figure 4. Probe connecting

A Long press power button until the device is turned on.If use alternating current,make sure that the power supply line is connected accurately and the alternating current switch is on.

B Do not shake the finger and keep the patient in a stable state during the process.

C The data can be read directly from the screen in the measure interface.

⚠ **Fingernails and the luminescent tube should be at the same side.**

⚠ **If the alarm function is on, the device will provide alarm signal when probe or finger is out.**

6.1.2 Alarm pause

A Alarm including the alarm of measure data's going beyond the limits, the alarm of low-voltage, the alarm of finger out.

B When alarm is on,short press the alarm pause button to make the alarm pause, it can renew alarm after period of time, alarm pause time can be set by menu.

C Only alarm sound can be closed,the prompt information displayed can't be closed.

6.1.3 Menu operations

In the measuring interface, press menu button to enter the main menu interface as figure 5.

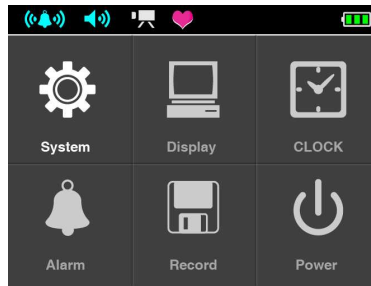



Figure 5. Main menu interface

 **System setting**

In the main menu interface, choose "System" item, then press menu button to enter the System setting menu as figure 6:

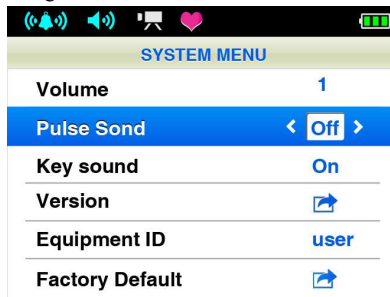

Figure 6. System setting menu

- A** Volume: move the choice bar to the "Volume" item, then press left/right button to set the volume (three levels, OFF means closing sound).
- B** Pulse sound: move the choice bar to the "Pulse sound" item, then press left/right button to set pulse sound.
- C** key sound: move the choice bar to the "key sound" item, then press left/right button to set key sound.
- D** Version: move the choice bar to the "Version" item, then press the menu button to see the edition information of hardware and software, and return to the system setting menu interface after 2 seconds .
- E** Equipment ID: see the ID information of device. The ID of the device can be set by the PC software. Please refer to <SpO₂ Assistant user manual> for detail.
- F** Factory Default: move the choice bar to the "Factory Default" item, then press the menu button to pop-up "Factory Default" window. Press up/down button to choose whether to resume Factory Default, and press menu button to affirm setting, then press return button to return the system setting menu interface.

Display setting

In the main menu interface, choose "Display" item, then press menu button to enter the display setting menu as Figure 7:

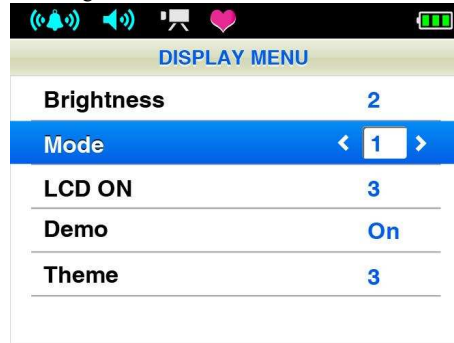

Figure 7. Display setting menu

A Brightness: move the choice bar to the "Brightness" item, then press left/right button to set (three levels)

B Mode: move the choice bar to the "Mode" item, then press left/right button to switch display mode (two kinds of display mode) as figure 7 and figure 8.

Note: in measure interface, the user could press mode switch button to switch display mode too.

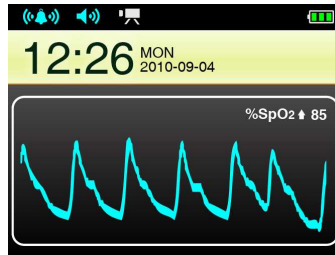

Figure 8. Interface 1

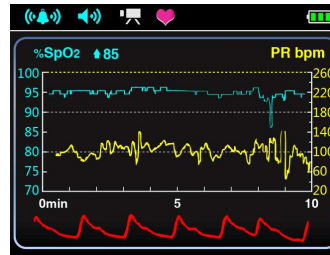

Figure 9. Interface 2

C LCD ON: move the choice bar to the "LCD ON" item, then press left/right button to set display time (range: 1~60min) .0 means display at all times

D Demo: move the choice bar to the "Demo" item, then press left/right button to turn on/off demo function.

E Theme: move the choice bar to "Theme" item, then press left/right button to set theme (Three kinds of theme are optional.)

Clock setting

In the main menu interface, move the choice bar to "Clock" item, then press the menu

button to enter the clock setting menu of Figure 10:



Figure 10. Clock setting menu

Move the choice bar to the menu item that you want to set, and press left/right button to begin to set. After resetting time, press return button to return to the main menu.



Alarm setting

In the main menu interface, move the choice bar to "Alarm" item, then press menu button to enter the alarm setting menu of Figure 11.

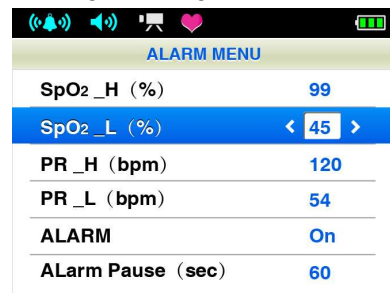

Figure 11. Alarm setting menu

A Set the high/low limit of alarm

In alarm setting menu, you can set the high/low limit of alarm. Move the choice bar to the menu item that you want to set, and press left/right button to set value, then press menu button for affirming.

⚠ If the alarm function is on, the device will provide alarm sound when the measure value is beyond the limit.

B Set alarm state

In alarm setting menu, move the choice bar to the "Alarm" item, press left/right to set the alarm state. Choose "on" to turn on the alarm, and choose "off" to turn off the alarm.

C Set alarm pause time

In alarm setting menu, move the choice bar to the "Alarm Pause" item, then press

left/right to set the alarm pause time. The range is 10~180s.

 **Record setting**

In the main menu interface, move the choice bar to "Record" item, then press menu button to enter record menu as Figure 12.

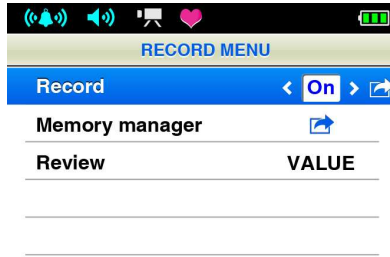

Figure 12. Record Menu

A Record setting

a In the record menu interface, move the choice bar to "Record" item, then press left/right button to choose on/off. When displaying "on", press menu button enter the input ID interface as Figure 13. When recording, choose "off", and press menu button to stop recording.

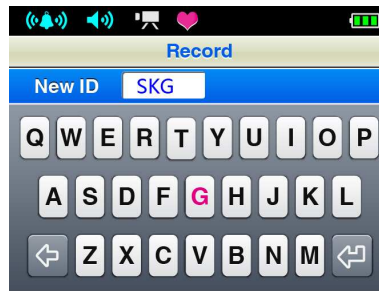



Figure 13. Input ID interface

b In "Input ID" interface, a glimmer cursor appears in the ID input box. The pink letter is the selected letter in dummy keyboard. Press direction key to choose the letter to input and press menu button to input. You can input 4 letters most. choose , then press menu button to delete letter. After inputting, choose , then press menu button to begin to record data and return to measure interface.

c If the inputted ID has existed, the prompt dialog box as figure 14 will appear. Choose "Yes" and click menu button to replace the existed ID, at the same time begin to record and return to the measure interface; choose "No" to return the "Input ID"

interface.

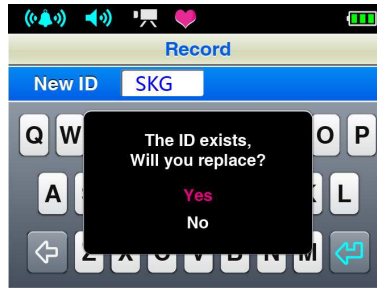

Figure 14. Replace the existed ID dialog box

- d Every patient ID could save 24-hour data,the device could save 16 patient ID.
 - e When the memory is full,the system will stop recording automatically.
 - f When the 16 groups of ID all have data,click "record" menu again,the device will appear "No Memory" dialog box.After deleting ID,the record can be continued.
- ⚠ If the device is restarted in the process of recording,the device will lose the segment of recording data.

⚠ In the process of recording,don't allow deleting and reviewing recording information.

B Memory Manager setting

In the Record menu interface,move the choice bar to the "Memory Manager" item,then press menu button to enter ID Manager interface as figure 15.

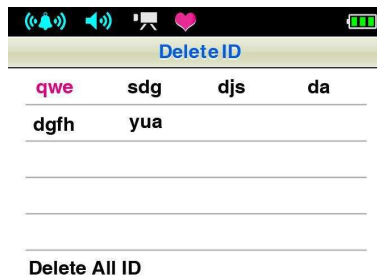

Figure15. ID Manager interface

In ID Manager interface,press direction button to choose ID or "Delete ID",and press menu button to prompt deleting operation as figure 16.Choose "Yes" and press menu button to delete ID.Choose "No" to return to the memory manager interface.

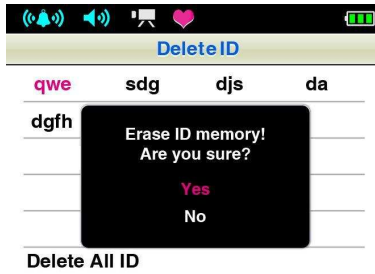

Figure 16. Delete ID dialog box

C Review function setting

In record menu interface,move the choice bar to the "Review" item,then choice frame will appear.Press the "left/right button" to choose "VALUE"/"TREND",then press menu button to enter "select ID" interface as figure 17.



Figure 17. Select ID interface

Choose the review record and press menu button to enter the review interface.Choose "VALUE" to enter true value review interface as figure 18.Choose "TREND" to enter trend review interface as figure 19.

Time	SpO ₂	PR	PI
11:32:24	98	74	0.0
11:32:25	96	69	0.0
11:32:26	97	70	0.0
11:32:27	88	69	0.0
11:32:28	96	73	0.0
11:32:25	98	69	0.0

Figure 18. VALUE review interface

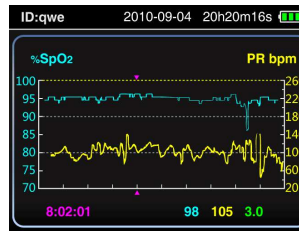

Figure19. TREND review interface

In value review mode,press "left button" or "right button" to page up or page

down,press "up button" or "down button" to page up or page down quickly.The displayed time on the right top is the total recording time.

In trend review mode ,the pink number on the left bottom is current recording time point of the trend graph,the middle azury font is SpO₂ value,yellow font is pulse rate value,the green front on the right bottom is PI value.Press "up button" or "down button" to page up or page down;press "left button" or "right button" to move the recording time which is denoted by pink triangle.

Close the device

a In the main menu interface, move the choice bar to the "Power " item,then press menu button to close the device.If the record function has been opened,the prompt interface of "Recording..." will appear when closing the device.It means that the device is in the record state,can't be closed.

b In the state of boot-strap,long press power button could close the device too.

6.1.4 PC software operation

Please connect the device to the computer by data line, then double click "SpO₂ Assistant" icon to run the PC software.The functions such as uploading real time/memory data and change device ID could be carried out by the software.Please refer to <SpO₂ Assistant user manual> for detail.

⚠If the users choose to turn on the display function on computer, it would probably take several seconds for the data to appear on the computer screen.(If there is no data on the computer screen ,unplug data line,then repeat step E again .)

6.1.5 Charge

Connect the device to power supply with power line,and make the power button on.

⚠When the device is closed and the battery is charging up,short press power button and the device will display dynamic charge icon ,it means that the device is charging up.When the battery status is full,the charging has been finished.When the device is open and the battery is charging up,the battery status icon on the right top will display dynamically.It means that the device is charging up.When the battery status is full,the charging has been finished.

6.2 Attention for Operation

A lease check the device before use, and confirm that it can work normally.

B The finger should be in a proper position (see the attached illustration of Figure 4 for reference), or else it may result in inaccurate measure.

C The ray between luminescent tube and photoelectric receiving tube must get across subject's arteriole.

- D** The device should not be used at a location or limb tied with arterial canal or blood pressure cuff or receiving intravenous injection.
- E** Ensure nothing, such as a plaster, can impede the light passage., or else it may result in inaccurate measure of SpO₂, pulse rate and PI.
- F** Excessive ambient light may affect the measure result. It includes fluorescent lamp, dual ruby light, infrared heater, direct sunlight and etc.
- G** Exquisite action of the subject or extreme electrosurgical interference may also affect the accuracy.
- H** Testee can not use enamel or other makeup.
- I** Please clean and disinfect the device after operating according to the User Manual (7.1).

6.3 Clinical Restrictions

- A** As the measure is taken on the basis of arteriole pulse, substantial pulsating blood flow of subject is required. For a subject with weak pulse due to shock, low ambient/body temperature, major bleeding, or use of vascular contracting drug, the SpO₂ waveform (PLETH) will decrease. In this case, the measure will be more sensitive to interference.
- B** For those with a substantial amount of staining dilution drug (such as methylene blue, indigo green and acid indigo blue), or carbon monoxide hemoglobin (COHb), or methionine (Me+Hb) or thiosalicylic hemoglobin, and some with icterus problem, the SpO₂ determination by this device may be inaccurate.
- C** The drugs like dopamine, procaine, prilocaine, lidocaine and butacaine may also be a major factor resulted in serious error of SpO₂ measure.
- D** As the SpO₂ value serves as a reference value for judgment of anemic anoxia and toxic anoxia, some patients with serious anemia may also report good SpO₂ measure.

7 Maintenance,Transportation and Storage

7.1 Cleaning and Disinfecting

Using medical alcohol to disinfect the device, nature dry or clean it with clean soft cloth.

7.2 Maintenance

A Please clean and disinfect the device before use according to the User Manual (7.1).

B Please recharge the battery when the screen shows low power alarm information.

C Recharge the battery soon after the over-discharge. The device should be recharged every six months when it is not regular used. It can extend the battery life following this guidance.

D Users are advised to calibrate the device termly (or according to the calibrating program of hospital). It also can be performed at the state-appointed agent or just contact us for calibration.

7.3 Transportation and Storage

















A The packed device can be transported by ordinary conveyance or according to transport contract.The device can not be transported mixed with toxic, harmful, corrosive material.













B The packed device should be stored in room with no corrosive gases and good ventilation. Temperature: -40°C~60°C; Relative Humidity: ≤95%

8 Troubleshooting

Trouble	Possible Reason	Solution
The SpO₂ and Pulse Rate can not be displayed normally	<ol style="list-style-type: none"> 1.The finger is not properly positioned. 2.The patient's SpO₂ is too low to be detected. 	<ol style="list-style-type: none"> 1.Place the finger properly and try again. 2.Try again/Go to a hospital for a diagnosis if you are sure the device works all right.
The SpO₂ and Pulse Rate are not displayed stably	<ol style="list-style-type: none"> 1.The finger is not placed inside deep enough. 2.The finger is shaking or the patient is moving. 	<ol style="list-style-type: none"> 1.Place the finger properly and try again. 2.Let the patient keep calm.
The device can not be turned on	<ol style="list-style-type: none"> 1.The battery is drained away or almost drained away. 2.The malfunction of the device. 	<ol style="list-style-type: none"> 1. Please recharge the battery 2. Please contact the local service center.
The display is off suddenly	<ol style="list-style-type: none"> 1.The device is damaged. 2.The battery is drained away or almost drained away. 	<ol style="list-style-type: none"> 1.Please contact the local service center. 2.Please recharge the battery.
The device can not be used for full time after charge	<ol style="list-style-type: none"> 1.The battery is not full charged. 2.The battery is broken 	<ol style="list-style-type: none"> 1.Please recharge the battery 2.Please contact the local service center.
The battery can not be full charged even after 10 hours charging time.	The battery is broken	Please contact the local service center.

9 Key of Symbols

Signal	Description
	Refer to instruction manual/booklet
	The pulse oxygen saturation (%)
	Pulse rate (bpm)
	Perfusion Index (%)
	The battery power is full
	fall short of power little
	Power is low
	Power is not enough
	Alarm indication: cyan-alarm on; yellow-alarm pause;white-alarm off
	Pulse sound indication:cyan- on;white-off
	Kinescope indication :when Kinescope-red;else circs-white
	PR indication:when there is pulse jumpiness, it glitters and flop
	Finger out (no finger)
	Power on/off button
	Type BF Applied Part(SpO2 Probe)
	USB
R	R pinhole Restoration key

SN	Serial number
Finger Out	Probe error Signal indication is not enough.
	WEEE (2002/96/EC)
EC REP	European Representative
	This item is compliant with Medical Device Directive 93/42/EEC of June 14, 1993, a directive of the European Economic Community.
	Alternating current indicator light
	Class II equipment
IP21	International Protection
	Manufacturer
	Date of manufacture
	Storage and Transport Temperature limitation
	Storage and Transport Humidity limitation
	Storage and Transport Atmospheric pressure limitation
	This side up
	Fragile, handle with care
	Keep dry
	Recovery

10 Function Specification

Information	Display Mode
Display Information	TFT 7"
The Pulse Oxygen Saturation(SpO ₂)	2-digit digital LED display
Pulse Rate(PR)	3-digit digital LED display
Pulse Intensity (bar-graph)	8-segment light bar LED display
PI (perfusion index)	3-digit digital LED display
SpO₂ Parameter Specification	
Measuring range	0~100%, (the resolution is 1%).
Accuracy	70%~100%:±2% ,Below 70% unspecified.
Pulse Parameter Specification	
Measuring range	30bpm~250bpm, (the resolution is 1bpm)
Accuracy	±2bpm or±2% (select larger)
Perfusion Index Specification	
Range	0~20% (The resolution is 0.1%)
Pulse Intensity	
Range	Continuous bar-graph display, the higher display indicates the stronger pulse.
Safety Type	II genus, Interior Battery,BF Type
Battery Requirement	
Voltage 3.7 rechargeable lithium battery × 1 (The red wire on the battery denotes anode,the black wire on the battery denotes cathode.).	
Time using: more than 8 hours.	
Time charging: less than 4 hours to full energy of battery.	
Battery working life	
Charge and discharge no less than 500 times.	
Power Requirement	
Input Voltage	AC 100 to 240V, 50/60 Hz
Dimensions and Weight	
Dimensions	269(L) × 222(W) × 79(H) mm
Weight	About 1kg (with a lithium battery)
Optional	
Thermal probe	Measuring and alarm range: 0~ 50°C Resolution: 0.1°C Accuracy: ±0.1°C Actualization interval: about 1 second

11 Factory Default

	default	unit
Brightness	3	
Measure interface display mode	1	
LCD Brightness time	0(mean display at all times)	
Demo mode	off	
Themes	3	
Alarm sound indication	on	
Alarm pause time	10	second
SpO ₂ alarm high limit	100	%
SpO ₂ alarm low limit	85	%
Pulse rate alarm high limit	120	bpm
Pulse rate alarm low limit	50	bpm

Appendix I

**Guidance and manufacturer's declaration – electromagnetic emissions-
for all EQUIPMENT and SYSTEMS**

Guidance and manufacturer's declaration – electromagnetic emission		
The CMS70A is intended for use in the electromagnetic environment specified below. The customer of the user of the CMS70A should assure that it is used in such and environment.		
Emission test	Compliance	Electromagnetic environment – guidance
RF emissions CISPR 11	Group 1	The CMS70A uses RF energy only for its internal function. Therefore, its RF emissions are very low and are not likely to cause any interference in nearby electronic equipment.
RF emission CISPR 11	Class B	The CMS70A is suitable for use in all establishments, including domestic establishments and those directly connected to the public low voltage power supply network that supplies buildings used for domestic purposes.
Harmonic emissions IEC 61000-3-2	Class A	
Voltage fluctuations/ flicker emissions IEC 61000-3-3	Complies	

**Guidance and manufacturer's declaration – electromagnetic immunity –
for all EQUIPMENT and SYSTEMS**

Guidance and manufacturer's declaration – electromagnetic immunity			
The CMS70A is intended for use in the electromagnetic environment specified below. The customer or the user of CMS70A should assure that it is used in such an environment.			
Immunity test	IEC 60601 test level	Compliance level	Electromagnetic environment - guidance
Electrostatic discharge (ESD) IEC 61000-4-2	±6 kV contact ±8 kV air	±6 kV contact ±8 kV air	Floors should be wood, concrete or ceramic tile. If floor are covered with synthetic material, the relative humidity should be at least 30%.
Electrical fast transient/burst IEC 61000-4-4	±2 kV for power supply lines	±2kV for power supply lines	Mains power quality should be that of a typical commercial or hospital environment.
Surge IEC 61000-4-5	±1 kV differential mode ±2 kV common mode	±1 kV differential mode ±2 kV common mode	Mains power quality should be that of a typical commercial or hospital environment.
Voltage dips, short interruptions and voltage variations on power supply input lines IEC	<5% U_T (>95% dip in U_T) for 0.5 cycle 40% U_T (60% dip in U_T) for 5 cycles	<5% U_T (>95% dip in U_T) for 0.5 cycle 40% U_T (60% dip in U_T)	Mains power quality should be that of a typical commercial or hospital environment.

61000-4-11	<p>70% U_T (30% dip in U_T) for 25 cycles</p> <p><5% U_T (>95% dip in U_T) for 5 sec</p>	<p>for 5 cycles</p> <p>70% U_T (30% dip in U_T) for 25 cycles</p> <p><5% U_T (>95% dip in U_T) for 5 sec</p>	
<p>Power frequency (50/60Hz) magnetic field IEC 61000-4-8</p>	3A/m	3A/m	<p>Mains power quality should be that of a typical commercial or hospital environment.</p>
<p>NOTE U_T is the a.c. mains voltage prior to application of the test level.</p>			

**Guidance and manufacture's declaration – electromagnetic immunity –
for EQUIPMENT and SYSTEMS that are not LIFE-SUPPORTING**

Guidance and manufacture's declaration – electromagnetic immunity			
The CMS70A is intended for use in the electromagnetic environment specified below. The customer or the user of CMS70A should assure that it is used in such an environment.			
Immunity test	IEC 60601 test level	Compliance level	Electromagnetic environment - guidance
Conducted RF IEC 61000-4-6	3Vrms 150 kHz to 80 MHz outside ISM bands	3 V _{rms} (for main power line) 1V _{rms} (for probe)	<p>Portable and mobile RF communications equipment should be used no closer to any part of the CMS70A, including cables, than the recommended separation distance calculated from the equation applicable to the frequency of the transmitter.</p> <p>Recommended separation distance</p> $d = \left[\frac{3.5}{V_1} \right] \sqrt{P}$ $d = \left[\frac{3.5}{E_1} \right] \sqrt{P} \quad 80 \text{ MHz to } 800 \text{ MHz}$ $d = \left[\frac{7}{E_1} \right] \sqrt{P} \quad 800 \text{ MHz to } 2.5 \text{ GHz}$ <p>where P is the maximum output power rating of the transmitter in watts (W) according to the transmitter manufacturer and d is the recommended separation distance in metres (m).</p> <p>Field strengths from fixed RF transmitters, as determined by an electromagnetic site survey,^a should be less than the compliance level in each frequency range.^b</p> <p>Interference may occur in the vicinity of equipment marked with the following symbol:</p> 
Radiated RF IEC 61000-4-3	3 V/m 80 MHz to 2.5 GHz	3 V/m	

NOTE 1 At 80 MHz and 800 MHz, the higher frequency range applies.			
NOTE 2 These guidelines may not apply in all situations. Electromagnetic propagation is affected by absorption and reflection from structures, objects and people.			
<p>^a Field strengths from fixed transmitters, such as base stations for radio (cellular/cordless) telephones and land mobile radios, amateur radio, AM and FM radio broadcast and TV broadcast cannot be predicted theoretically with accuracy. To assess the electromagnetic environment due to fixed RF transmitters, an electromagnetic site survey should be considered. If the measured field strength in the location in which the CMS70A is used exceeds the applicable RF compliance level above, the CMS70A should be observed to verify normal operation. If abnormal performance is observed, additional measures may be necessary, such as re-orienting or relocating the CMS70A.</p>			
<p>^b Over the frequency range 150 kHz to 80 MHz, field strengths should be less than 3 V/m .</p>			

**Recommended separation distances between portable and mobile
RF communications equipment and the EQUIPMENT or SYSTEM –
for EQUIPMENT or SYSTEM that are not LIFE-SUPPORTING**

Recommended separation distances between portable and mobile RF communications equipment and the CMS70A				
The CMS70A is intended for use in an electromagnetic environment in which radiated RF disturbances are controlled. The customer or the user of the CMS70A can help prevent electromagnetic interference by maintaining a minimum distance between portable and mobile RF communications equipment (transmitters) and the CMS70A as recommended below, according to the maximum output power of the communications equipment.				
Rated maximum output power of transmitter (W)	Separation distance according to frequency of transmitter (m)			
	150 kHz to 80 MHz $d = \left[\frac{3.5}{V_1} \right] \sqrt{P}$	80 MHz to 800 MHz $d = \left[\frac{3.5}{E_1} \right] \sqrt{P}$	800 MHz to 2.5 GHz $d = \left[\frac{7}{E_1} \right] \sqrt{P}$	
	Main power line	probe		
0.01	0.12	0.35	0.12	0.23
0.1	0.37	1.11	0.37	0.74
1	1.2	3.50	1.17	2.33
10	3.7	11.07	3.69	7.38
100	12	35.00	11.67	23.33
For transmitters rated at a maximum output power not listed above, the recommended separation distance d in metres (m) can be estimated using the equation applicable to the frequency of the transmitter, where P is the maximum output power rating of the				

transmitter in watts (W) according to the transmitter manufacturer.

NOTE 1 At 80 MHz and 800 MHz, the separation distance for the higher frequency range applies.

NOTE 2 These guidelines may not apply in all situations. Electromagnetic propagation is affected by absorption and reflection from structures, objects and people.

Recommended separation distances between portable and mobile

**RF communications equipment and the EQUIPMENT or SYSTEM –
for EQUIPMENT or SYSTEM that are not LIFE-SUPPORTING**

Recommended separation distances between portable and mobile RF communications equipment and the CMS70A				
The CMS70A is intended for use in an electromagnetic environment in which radiated RF disturbances are controlled. The customer or the user of the CMS70A can help prevent electromagnetic interference by maintaining a minimum distance between portable and mobile RF communications equipment (transmitters) and the CMS70A as recommended below, according to the maximum output power of the communications equipment.				
Rated maximum output power of transmitter (W)	Separation distance according to frequency of transmitter (m)			
	150 kHz to 80 MHz	80 MHz to 800 MHz	800 MHz to 2.5 GHz	
	$d = \left[\frac{3.5}{V_1} \right] \sqrt{P}$	$d = \left[\frac{3.5}{E_1} \right] \sqrt{P}$	$d = \left[\frac{7}{E_1} \right] \sqrt{P}$	
	Main power line	probe		
0.01	0.12	0.35	0.12	0.23
0.1	0.37	1.11	0.37	0.74
1	1.2	3.50	1.17	2.33
10	3.7	11.07	3.69	7.38
100	12	35.00	11.67	23.33
For transmitters rated at a maximum output power not listed above, the recommended separation distance d in metres (m) can be estimated using the equation applicable to the frequency of the transmitter, where P is the maximum output power rating of the				

transmitter in watts (W) according to the transmitter manufacturer.

NOTE 1 At 80 MHz and 800 MHz, the separation distance for the higher frequency range applies.

NOTE 2 These guidelines may not apply in all situations. Electromagnetic propagation is affected by absorption and reflection from structures, objects and people.

